

FPM4000DF

*Sunbeam*

**DIAMONDFORCE™  
BANQUET FRYPAN**

User Guide



\*Matrix shown on product is for illustrative purposes only

# Contents

<b>Sunbeam's Safety Precautions</b>	<b>1</b>
<b>Features of your Sunbeam DiamondForce Banquet Frypan</b>	<b>2</b>
<b>Parts &amp; Accessories</b>	<b>4</b>
<b>Usage Instructions</b>	<b>4</b>
<b>Care &amp; Cleaning</b>	<b>6</b>
<b>Temperature Setting Guide</b>	<b>7</b>
<b>Cooking Guide</b>	<b>8</b>
<b>Recipes</b>	<b>10</b>
<b>Troubleshooting</b>	<b>23</b>

## Important instructions – retain for future use.

تأكد من تفهم احتياطات السلامة المذكورة اعلاه

請務必理解上述的安全預防措施。

Assurez-vous que les précautions ci-dessus relatives à la sécurité sont bien comprises

Versichern Sie sich, dass die obenstehenden Sicherheitsmaßnahmen Verstanden werden

Βεβαιώσετε πως οι παραπάνω προφυλάξεις ασφαλείας γίνονται κατανοητές

Pastikan bahwa tindakan-tindakan keselamatan seperti di atas dimengerti anda

Accertatevi che le suddette norme di sicurezza siano comprese a dovere

上記の注意事項をよくお読みになり、安全を御確認ください

Уверете се дека погоре споменатите мерки на претпазливост се добро разбрани

Asegúrese de que las precauciones de seguridad precedentes sean bien comprendidas

کاری بکنید کہ احتیاطهای بالا حتماً درک بشوند

ต้องแน่ใจว่า ข้อควรระวังเรื่องความปลอดภัยข้างต้น เป็นที่เข้าใจกันดี

Yukarda belirtilen güvenlik önlemlerinin anlaşılığından emin olunuz

Xin kiểm chắc rằng những biện pháp làm an toàn kể trên được hiểu rõ

# Sunbeam's Safety Precautions

## SAFETY PRECAUTIONS FOR YOUR SUNBEAM DIAMONDFORCE™ FRYPAN.

- Use your frypan at least 200mm away from walls and curtains.
- Do not immerse the control probe in water.
- If using a plastic spatula do not leave in cooking vessel when hot.
- The frypan must only be used with the control probe provided.
- Avoid using on metal surfaces e.g. sink, hotplate.
- Remove the control probe before cleaning the frypan.
- After cleaning the frypan ensure that the control probe Inlet area is completely dry before using again.

**Sunbeam is very safety conscious when designing and manufacturing consumer products, but it is essential that the product user also exercise care when using an electrical appliance. Listed below are precautions which are essential for the safe use of an electrical appliance:**

- Read carefully and save all the instructions provided with the appliance.
- Always turn the power off at the power outlet before you insert or remove a plug. Remove by grasping the plug - do not pull on the cord.
- Turn the power off and remove the plug when the appliance is not in use and before cleaning.
- Do not use your appliance with an extension cord unless this cord has been checked and tested by a qualified technician or service person.
- Always use your appliance from a power outlet of the voltage (A.C. only) marked on the appliance.
- Children should be supervised to ensure that they do not play with the appliance.
- Use well away from walls and curtains.
- Do not use in confined spaces.
- Never leave an appliance unattended while in use.
- Do not use an appliance for any purpose other than its intended use.
- Do not place an appliance on or near a hot gas flame, electric element or on a heated oven.
- Do not place on top of any other appliance.
- Do not let the power cord of an appliance hang over the edge of a table or bench top or touch any hot surface.
- Do not operate any electrical appliance with a damaged cord or after the appliance has been damaged in any manner. If damage is suspected, return the appliance to the nearest Sunbeam Appointed Service Centre for examination, repair or adjustment.
- For additional protection, Sunbeam recommend the use of a residual current device (RCD) with a tripping current not exceeding 30mA in the electrical circuit supplying power to your appliances.
- Do not immerse the appliance in water or any other liquid unless recommended.
- Appliances are not intended to be operated by means of an external timer or separate remote control system.
- This appliance is intended to be used in household and similar applications such as: staff kitchen areas in shops, offices and other working environments; farm houses; by clients in hotels, motels and other residential type environments; bed and breakfast type environments.
- Refer to "Care and Cleaning" section for details concerning precautions during use maintenance.
- Cleaning and user maintenance shall not be made by children unless they are older than 8 and supervised.
- Keep the appliance and its cord out of reach of children less than 8 years old.
- This appliance is not intended for use by persons (including children) with reduced physical, sensory or mental capabilities, or lack of experience and knowledge, unless they have been given supervision or instruction concerning use of the appliance by a person responsible for their safety.



### Hot Surface Do Not Touch

This symbol indicates, temperature of accessible surfaces may be high when the appliance is operating and for some time after use.

If you have any concerns regarding the performance and use of your appliance, please visit [www.sunbeam.com.au](http://www.sunbeam.com.au) or contact the Sunbeam Consumer Service Line. Ensure the above safety precautions are understood.

# Features of your Sunbeam DiamondForce™ Banquet Frypan

---

## Integrated steam vent

Fixed steam vent controls the moisture level during cooking.

---

## DiamondForce™ non-stick cooking surface

The DiamondForce™ coating advantage with advanced non-stick performance provides superior food release, requiring little to no oil when cooking food and easy wipe clean up.

---

## Cool touch handles and lid knob

For safer cooking and carrying of the frypan

---

## Control probe inlet

---

## Tilt & baste lever

When the lever is in the lowered position the cooking pan is tilted, forcing juices to collect at one end of the pan. Both hands are then free for basting.

---

## Dishwasher safe

The pan, base and lid are dishwasher safe and fully immersible making cleaning a breeze.

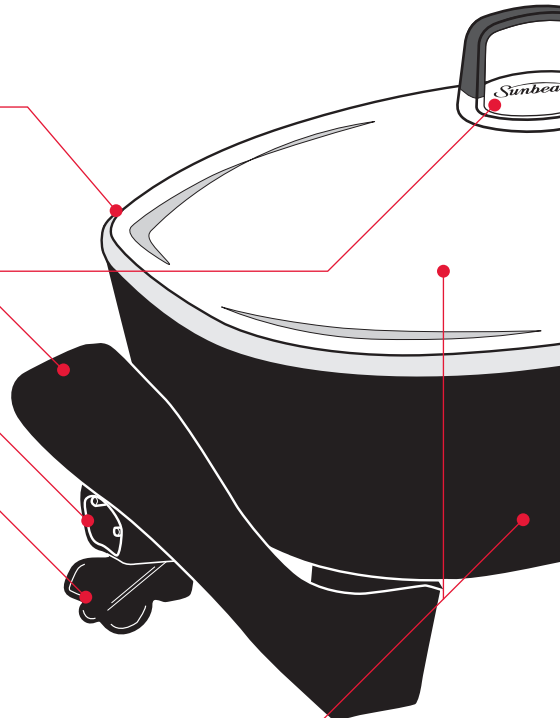

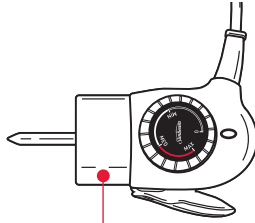

### **Perfect Temp control probe**

The removable probe is thermostatically controlled to provide accurate cooking temperatures. The trigger-release makes the probe easy to remove.

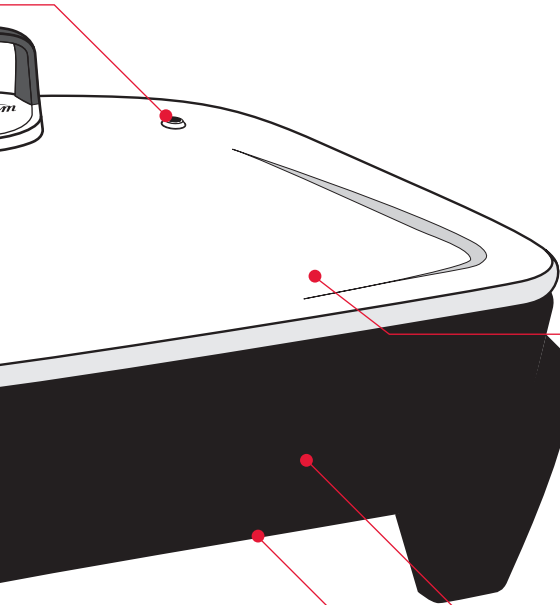

### **Glass lid**

The clear glass lid allows you to monitor the cooking process without lifting the lid and allowing the heat to escape, ensuring the selected temperature is maintained.

### **Extra large cooking vessel**

The large rectangular frypan (38cm (15") x 29.5cm (11.5")) is 78mm deep, ideal for cooking 2 chickens, roasts, family size meals or liquid based dishes.

### **Cast-in rectangle element**

The powerful 2400 watt rectangle element is completely cast into the heavy duty base providing superior heat distribution, faster heating and a longer element life.

# Parts & Accessories

## **Trigger-Release Control Probe**

The heat control probe is thermostatically controlled to deliver perfect cooking control.

The indicator light switches 'on' when it is heating. When the frypan has reached the desired temperature the indicator light switches 'off'. The indicator light will then cycle 'on' and 'off' as the thermostat maintains the set temperature.

The heat control probe is ergonomically designed with a handy trigger-release. Simply hold the probe and squeeze the trigger with your thumb to remove it.

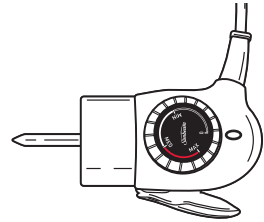

Heat control probe with trigger release

# Usage Instructions

## Before First Use

Before using your Frypan for the first time, remove all packaging and promotional materials from the product and control probe.

With the control probe detached, wash with warm soapy water using a mild household detergent.

Rinse thoroughly and dry. Make sure the interior of the probe inlet is fully dry.

**Note: Do not immerse the heat control probe in water or any other liquid.**

## Using your Frypan

1. Place on a flat, level, heat-resistant surface.
2. Insert the control probe fully into the probe inlet of the frypan.
3. Plug the cord into 230-240V power outlet and turn the power on.
4. Pre heat the frypan on MED/MAX setting. Then set the control probe dial to the desired temperature setting. Refer to page 9 for the temperature guide.

**Note:** The thermostat light on the control probe indicates the temperature at which the dial is set. The light will remain on until the set temperature has been reached and then will cycle on and off throughout the cooking. This will ensure that the frypan maintains the correct temperature. On the initial heating of the frypan, it is recommended that the temperature be allowed to cycle (the light cycling on and off) several times. This will help the cooking surface to adjust to a more accurate cooking temperature.

5. After you have completed cooking, turn the power OFF and unplug from the power outlet.

**Note:** Ensure the cord is kept well away from the frypan when in use.

**Caution:** Do not touch the frypan when in use. Avoid touching hot surfaces. Take care when removing food from the frypan. Do not transport the frypan when it is hot.

## Using the tilt & baste lever

The tilt & baste lever of the frypan is positioned under the inlet where the control probe is inserted. To tilt the frypan, push the lever down. This allows the fat and juices to drain from the food for crisp, low fat cooking. It also makes it easier to baste food and serve sauces or gravy.

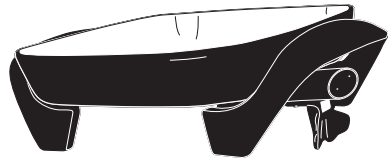

# Care & Cleaning

Use heat-resistant plastic or wooden or silicone utensils when cooking on the frypan. Avoid using sharp or metal objects as these will scratch the non-stick surface. Do not cut food on top of the cooking surface. Do not leave plastic utensils in contact with the cooking surface while in use.

## To clean after use

Always turn the power off and remove the plug from the power outlet and the control probe from the probe inlet before cleaning. Allow the frypan to cool before cleaning.

## DiamondForce™ non-stick coating

When cleaning with the DiamondForce™ non-stick coating, do not use metal (or other abrasive scourer). When the frypan has cooled down, you may wipe using a paper towel to remove residue on the frypan. With the control probe detached, wash with warm soapy water using a mild household detergent. Rinse thoroughly and dry the frypan with a soft cloth before storing. Make sure the interior of the probe inlet is fully dry.

## Heat Control probe

If cleaning is necessary, wipe over with a damp cloth.

**Note:** The control probe must be removed before the frypan is cleaned and the control probe inlet must be dried before the frypan is used again.

**Important: Do not immerse the control probe in water or any other liquid. Store the control probe carefully. Do not knock or drop it as this can damage the probe.**

## Storage

Store the control probe carefully in a safe place. Do not knock or drop it as this can damage the probe.

If damage is suspected, return the control probe to your nearest Sunbeam Service Centre for inspection.

## Glass lid

Wash the lid in warm soapy water using a soft sponge, rinse and dry thoroughly. Alternatively, wash the lid in a dishwasher.

# Temperature Setting Guide

The settings on the dial represent the following temperatures approximately. Pre-heat your frypan on MAX setting then change to your desired setting.

DIAL SETTING	CELCIUS (approx)	USES	TEMPERATURE
MIN	50°C - 70°C	Keeping food warm	LOW
MIN/MED	80°C - 105°C	Simmering, slow cooking	
MED	120°C - 140°C	Pan frying	MEDIUM
MED/MAX	150°C - 175°C	Shallow frying, roasting	
MAX	190°C - 210°C	Searing and sealing	HIGH

**Note:** The temperature settings are a guide only and may require adjustment to suit various foods and individual tastes. When the dial is set to a MIN setting, it is quite normal for food to stop and start bubbling, as the thermostat maintains the selected temperature.

# Cooking Guide

## Baking

Your frypan can be used for baking cakes, with deliciously moist results.

1. Preheat the frypan to MAX setting, with the lid on.
2. Elevate the cake pan or tray from the base of the frypan using a small wire rack.

Cooking times will be longer than those of a conventional oven.

## Basting

The tilt & baste lever makes basting easy as it allows the juices to drain to one side of the pan. Reduce the temperature to prevent any fat and juices splattering. Position the pan tilt lever and spoon the juices over the food as desired.

## Browning and Sealing Meat

It is necessary to brown and seal meat in many recipes. Meat retains its juices and the flavours develop after browning and sealing. This also prevents it from sticking when baking or roasting. Preferably use meat that is at room temperature, as this reduces the cooking time.

1. Preheat the frypan to MED/MAX setting.
2. Brown meat on all sides, with the lid off.
3. After sealing, reduce the temperature to MED setting and replace the lid until the meat is cooked as desired.

## Frying

The frypan is ideal for shallow or dry frying. Deep frying is not particularly suitable as the frypan has shallow sides and a greater surface area, which results in heat loss and the possible overflow of oil.

**Pan frying:** Suitable for eggs, omelettes, bacon, sausages, steaks and chicken pieces. Preheat to MED setting with a little oil to add flavour. Non-stick cooking surfaces do not require a large amount of oil. Steaks should only be turned once during cooking.

**Shallow frying:** Suitable for vegetable pieces e.g roast pumpkin and potato, and crumbed food. Preheat on MED setting with sufficient oil so that the food is half immersed. Cook food with the lid off.

**Sautéing:** Preheat on MED setting with a little oil to add flavour.

**Stir frying:** Food is cooked quickly, over a high heat and vegetables retain their flavour and crispness. For best results and even cooking, cut food into even sized, smaller pieces.

1. Preheat the frypan on MED/MAX setting with a little oil.
2. Slice meat into strips. Coat meat in a little oil and stir-fry in batches until browned. This prevents meat from stewing.
3. Add vegetables and seasoning, stirring continuously. Vegetables which take longer to cook, such as carrots, should be cooked first, adding the other ingredients later. Cook until the vegetables are crisp. Return the meat back into the pan when the vegetables are almost cooked. The lid can be in position in the last few minutes of cooking.

# Cooking Guide

## Roasting

**Meat and poultry:** The frypan is ideal for roasting meat and poultry, as the meat retains the flavour and juices.

1. Preheat the frypan to MED/MAX setting. Use only a small amount of oil for less fatty joints and no oil for fattier joints of meat.
2. Brown and seal the meat on all sides and position the lid.
3. After browning, turn the dial to MED setting to cook the meat as desired. Turn meat occasionally during cooking to ensure even cooking.
4. Remove meat from pan and cover with foil. Allow meat to rest for 5-10 minutes, meanwhile you can make a gravy from the juices in the frypan.

**Vegetables:** Cut into even sized pieces. Add to the frypan 45-60 minutes before serving. For crisper vegetables, remove the meat and increase the heat for the last few minutes of cooking.

## Roasting times:

**Note:** These times are for well done. Reduce the times to suit personal taste.

PORK	30-40 minutes per 500g after browning.
VEAL	30-40 minutes per 500g after browning.
BEEF	20-25 minutes per 500g after browning.
LAMB	25-30 minutes per 500g after browning.
CHICKEN	30-35 minutes per 500g after browning.

# Recipes

All recipes have been specifically created and tested by the Sunbeam Test Kitchen for the Frypan. We hope you enjoy using your Sunbeam Frypan.

---

## Minestrone

### Serves 4-6

- 1 tablespoon olive oil
  - 1 onion, diced finely
  - 2 cloves garlic, crushed
  - 1 carrot, diced finely
  - 2 trimmed celery stalks, diced finely
  - 1 bacon bone (200g)
  - 800g can chopped tomatoes
  - 6 cups water
  - 1 cup finely chopped savoy cabbage
  - 2 small zucchini, diced
  - 1 x 400g can cannellini beans, rinsed and drained
  - $\frac{3}{4}$  cup small pasta
  - Sea salt and freshly ground black pepper
  - shaved parmesan, to serve
1. Heat oil in frypan on MED setting. Cook onion and garlic until translucent. Add carrot, celery and bacon bone and cook, stirring occasionally for 5 minutes.
  2. Add the chopped tomatoes and water and bring the soup to the boil. Reduce heat to MIN setting and cook, covered for 45 minutes.
  3. Add the cabbage, zucchini, beans, pasta and season with salt and pepper. Cook, covered for a further 20-25 minutes. Add a little extra water if necessary.
  4. Serves hot with shavings of parmesan on top.

## Pumpkin Soup

### Serves 4

- 1.5 kg pumpkin, peeled, seeds removed
  - 2 tablespoons olive oil
  - 20g butter
  - 1 large onion, chopped
  - 1 litre low salt chicken stock
  - Sea salt & freshly ground black pepper
  - $\frac{1}{3}$  cup cream or sour cream to serve (optional)
1. Heat oil and butter in frypan on MED setting. Add onions and cook, stirring, until the onions have softened. Add pumpkin and cook for a further 3-4 minutes, stirring occasionally.
  2. Add the stock and bring to the boil. Reduce heat to MIN/MED setting and cook, covered for 30 minutes. Cool before blending.
  3. Blend or process soup until smooth. Return pureed soup to frying pan.
  4. Reheat until soup is hot. Serve with cream and extra ground pepper if desired.

# Recipes

## Corn Fritters

### Makes approx. 20

1 cup self raising flour  
½ teaspoon bicarbonate soda  
½ teaspoon sweet paprika  
½ teaspoon ground coriander  
⅔ cup buttermilk  
2 eggs  
2 cups corn kernels  
1 small red capsicum, diced finely  
3 small green onions, sliced  
2 tablespoons chopped fresh parsley  
1 tablespoon chopped fresh coriander  
Sea salt and freshly ground black pepper  
Olive oil  
Tomato chilli jam, to serve

1. Combine flour, soda, paprika in a bowl; whisk through buttermilk and eggs to form a batter.
2. Combine corn, capsicum, green onions, parsley and coriander in a large bowl. Stir through the batter; season with salt and pepper.
3. Heat frypan on MED/MAX setting. Drizzle a little olive oil in frypan and spoon tablespoonfuls of mixture into pan. Cook fritters for 2-3 minutes on each side until golden.
4. Serve with tomato chilli jam if desired.

## Gyoza (Japanese Dumplings)

### Makes approx. 50

150g pork mince  
150g chicken mince  
2 tablespoons kecap manis (sweet soy)  
1 teaspoon sugar  
1 tablespoon mirin  
1 egg  
2 teaspoons sesame oil  
2½ cups Chinese cabbage, shredded finely  
⅓ cup finely chopped water chestnuts  
4 green onions, chopped finely  
50 sheets gow gee wrappers  
vegetable oil for pan frying

### Dipping Sauce

2 tablespoons kecap manis  
1 tablespoon black vinegar

1. Combine all ingredients in a bowl and mix well.
2. Lay several sheets of gow gee wrappers out onto a bench top. Have a tray lined with baking paper ready to place the prepared gyoza onto.
3. Place a rounded teaspoon of filling into the centre of the wrapper. Moisten the edges with a little water. Fold the wrapper over the filling but before sealing carefully pleat on one side. The pastry will look plain on one side but have a small pleat on the other. Gently press the pastry to seal. Repeat with remaining wrappers.
4. Heat frypan on MED/MAX setting. Heat 1 tablespoon of oil in the frying pan and place the dumplings, in batches, into the pan, pleat side up. Cook until the dumplings are golden on the bottom. Do not turn. Carefully pour enough water in the frying pan so that the dumplings are

# Recipes

half covered. Place the lid on the frypan and cook, covered for 1 minute. Remove lid and cook, uncovered, until all the water has evaporated. Remove from pan, repeat with remaining dumplings.

**Note:** The water should be simmering the entire time. If this does not happen increase the heat to MAX setting.

5. Serve with dipping sauce.

**Tip:** Kecap manis, mirin and black vinegar are available at Asian grocery stores, or in the international section of supermarkets.

## Soy Sauce Chicken Wings

### Serves 4

- 1½ kg chicken wings
- ½ cup honey
- ½ cup low salt soy sauce
- 2 teaspoons shao hsing cooking wine
- 2 cloves garlic, crushed
- 3 teaspoons grated fresh ginger

1. Cut wings at joints and discard tips.
2. Combine remaining ingredients in a jug.
3. Place wings in a single layer in electric frypan. Pour sauce over wings and turn to coat.
4. Turn electric frypan onto MED setting. Cook wings, turning occasionally. Cook for about 30 minutes or until browned and cooked through.

5. Serve with rice.

**Tip:** Shao hsing is a Chinese cooking wine and is available from Asian supermarkets. If unavailable then recipe can be substituted with sweet sherry.

## Chilli Crab

### Serves 4

- 6 raw blue swimmer crabs
- 3 green onions
- 2 tablespoons peanut oil
- 3 cloves garlic, chopped
- 1 large red chilli, chopped
- 3 teaspoons grated fresh ginger
- ½ cup tomato sauce
- ½ cup sweet chilli sauce – smooth paste variety
- 1 tablespoon oyster sauce
- 1 tablespoon fish sauce
- ½ cup chicken stock
- 1 tablespoon grated palm sugar
- Steamed jasmine rice, to serve

1. Remove flap from the undersides of crabs then flip crab over. Place your thumb under the shell between the two back legs and slowly pull the shell away from the body. Discard. Remove the feather-like gills and front feelers and discard. Carefully rinse the crab if needed – do not put under running water. Using a sharp knife cut the body in half; then cut between the smaller legs to make 4 pieces. Crack the large nippers with crab crackers; this will help the heat get into the shell.
2. Slice green onions and separate the green ends from the white; set aside.
3. Heat oil in electric frypan on MED/MAX setting. Add whites of onions, garlic, chilli and ginger to pan and cook, stirring, until fragrant.
4. Reduce heat to MED setting and add crabs. Combine remaining ingredients and pour over crabs. Stir crabs gently to coat then cook, covered, stirring occasionally for about 15 minutes or until the crabs have gone a deep orange colour and are just cooked through.

# Recipes

**Tip:** A good way to see if the crabs are cooked is to check the joint on the large nipper. When these have changed colour your crabs should be cooked through.

5. Remove crabs from frypan onto a large serving platter and spoon over sauce from frypan. Sprinkle with sliced green onions.
6. Serve with steamed jasmine rice.

## Spanish Paella

### Serves 6-8

- 2 small raw blue swimmer crabs
- 8 large green prawns
- 8 small black mussels
- 3½ cups fish/chicken stock
- 1 teaspoon saffron threads
- 180g chorizo sausage, sliced
- 200g chicken thighs, halved
- 1 tablespoon extra virgin olive oil
- 1 medium onion, chopped finely
- 1 clove garlic, crushed
- ¼ teaspoon smoked paprika
- 1 x 400g canned tomatoes
- 1½ cups Arborio or Spanish rice
- 300g whole pipis, purged
- ½ cup frozen peas
- 1 small roasted red capsicum, sliced

1. Remove flap from the undersides of crabs then flip crab over. Place your thumb under the shell between the two back legs and slowly pull the shell away from the body. Discard. Remove the feather-like gills and front feelers and discard. Carefully rinse the crab if needed – do not put under running water. Using a sharp knife cut the body in half; then cut between the smaller

legs to make 4 pieces. Crack the large nippers with crab crackers; this will help the heat get into the shell.

2. Peel four of the prawns and devein. Leave the other four whole for presentation. Clean and de-beard mussels.
3. Place stock and saffron in a saucepan and heat gently to infuse. Cover and keep warm.
4. Heat the electric frypan on MED/MAX setting. Cook chorizo in pan until golden; drain on paper towelling.
5. In same pan cook the chicken thighs and whole prawns in chorizo oil until just cooked through; set aside.
6. Reduce heat to MED setting and add extra virgin olive oil, if needed, in electric frypan and cook onions and garlic until the onions are translucent; add paprika and cook for a further 30 seconds.
7. Add tomatoes and cook on MED setting for 2-3 minutes. Add rice and cook, stirring until well coated. Add stock and stir to combine. Reduce heat to MIN/MED setting and cook, covered for 10 minutes.
8. After 10 minutes check rice, add a little water if the rice looks too dry. Cook, covered, for a further 5 minutes if the rice is still quite hard.
9. Arrange raw seafood, chicken, chorizo, whole prawns, peas, roasted capsicum, over rice and cook, covered for a further 5 minutes or until the seafood is cooked and the rice is tender. Turn heat off and keep covered for 5 minutes before serving.

# Recipes

## Family Beef Casserole with Semi Dried Tomatoes

**Serves 6-8**

- 2 kg chuck steak, cut into 2cm cubes
  - ½ cup flour
  - 3 tablespoons olive oil
  - 2 bunches of spring onion, stalk trimmed, peeled and left whole
  - 2 cloves garlic, crushed
  - ⅓ cup tomato paste
  - ½ cup red wine
  - 3 carrots, diced
  - 3 celery stalks, sliced
  - 1 cup beef stock
  - 1 cup water
  - 2 tablespoons chopped fresh thyme
  - 2 bay leaves
  - 1 cup semi dried tomatoes
  - Salt and freshly ground black pepper
1. Dust beef in flour, shaking off excess flour. Heat oil in frypan and cook beef in batches until brown. Set aside.
  2. To the same pan, add onion and garlic, cook, stirring for 1-2 minutes, or until onion starts to colour. Stir through tomato paste and cook for 1 minute.
  3. Add wine and allow alcohol to evaporate and liquid to reduce slightly. About 2 minutes.
  4. Place beef, vegetables, stock, water, thyme and bay leaves in frypan. Cover and cook on setting 4 for 1 hour, stirring occasionally. After 1 hour add tomatoes and cook for a further 20-30 minutes or until beef is tender.
  5. Season to taste and serve hot with mashed potatoes or rice.

## Pan Fried Chicken Breast with Salsa Verde

**Serves 6**

- 1-2 tablespoons olive oil
  - 6 chicken breast fillets
- ### Salsa Verde
- 1 cup fresh flat leaf parsley
  - ½ cup dill
  - ½ cup fresh mint leaves
  - 2 cloves garlic
  - 1 tablespoon small capers
  - 1 tablespoon grated lemon rind
  - Sea salt and freshly ground black pepper
  - ¾ cup extra virgin olive oil

1. Heat frypan on MED/MAX setting. Add oil and cook chicken, uncovered, until browned on both sides and cooked through. Remove from heat and serve with Salsa Verde.
2. To make the Salsa Verde, blend or process all ingredients until a chunky sauce texture is achieved.

**Tip:** Salsa Verde also goes very well with pan fried fish fillets.

# Recipes

## Pan Fried Fish with Garlic and Lemon

### Serves 4

4 (800g) white fish fillets  
2 tablespoons olive oil  
2 cloves garlic, crushed  
2 tablespoons lemon juice  
2 eschalots, minced  
¼ cup shredded fresh basil leaves  
Sea salt and freshly ground black pepper  
Steamed new potatoes or mash, to serve  
Steamed broccolini, to serve

1. Place fish in a shallow baking dish.  
In a small bowl combine the garlic, lemon juice, eschalots, basil, salt and pepper and mix well.
2. Pour marinade over fish and allow to sit at room temperature for 20 minutes.
3. Heat frypan on MAX setting. Add oil and cook fish for 3-5 minutes on both sides until just cooked through.

**Note:** Cooking time will vary depending on the thickness of each fillet.

4. Serve fish with potatoes and steamed broccolini.

## Beef Stroganoff

### Serves 4

2 tablespoons plain flour  
1 kg beef strips  
2 tablespoons olive oil  
2 small cloves garlic, crushed  
¼ cup tomato paste  
1 cup beef stock  
250g button mushrooms, sliced  
½ cup sour cream  
Salt and freshly ground black pepper

1. Dust beef in flour, shaking off excess flour.  
Heat oil in frypan on MED setting; cook beef in batches until browned.
2. Return all beef to pan and add remaining ingredients, except sour cream. Cover and cook on MIN/MED setting for about 45 minutes or until the beef is tender.
3. Stir through sour cream. Season with salt and pepper. Serve with buttered noodles.

# Recipes

## **Creamy Oyster Chicken**

### **Serves 4**

800g chicken tenders  
¼ cup flour  
1 tablespoon olive oil  
300ml cream  
¼ cup oyster sauce  
200g small button mushrooms, quartered  
Salt and freshly ground black pepper  
steamed broccoli, to serve  
steamed rice, to serve

1. Lightly coat chicken in flour. Heat oil in frypan on MED/MAX setting. Cook chicken, in batches, until golden on each side. Remove from pan. The chicken should not be completely cooked through at this stage.
2. Add cream and oyster sauce to frypan; stir to combine. Add mushrooms and cook for 1 minute. Return chicken to frypan and cook, stirring occasionally until the sauce has thickened and the chicken is cooked through.
3. Serve with steamed broccoli and rice.

## **Steamed Salmon Parcels**

### **Serves 4**

4 x 180g Atlantic salmon fillets  
1 stalk lemon grass, white only, chopped finely  
4 eschalots, sliced thinly  
½ cup fresh coriander leaves  
1 large red chilli, seeded, sliced  
2 cloves garlic, crushed  
2 teaspoons grated fresh ginger  
½ cup coconut milk  
Salt and freshly ground black pepper  
1 tablespoon peanut oil  
4-6 baby bok choy, quartered  
Steamed jasmine rice, to serve

1. Preheat electric frypan on MED/MAX setting with the lid on for 5 minutes.
2. Combine the lemon grass, eschalots, coriander, chilli, garlic, ginger, coconut milk and salt and pepper in a bowl and mix well.
3. Place each piece of salmon on four individual pieces of baking paper. Divide the coconut mixture evenly over the tops of the salmon. Fold each piece of foil up to make four sealed parcels.
4. Place parcels in frypan and cook, covered, on MED setting for about 12-15 minutes or until cooked as desired. Remove from heat.
5. Quickly increase heat in electric frypan and heat oil; toss bok choy for 1-2 minutes until wilted; season with salt and pepper.
6. Serve salmon with bok choy and steamed jasmine rice.

# Recipes

## Dhal

### Serves 4-6

1 tablespoon vegetable oil  
1 medium onion, finely chopped  
1 clove garlic, crushed  
3 teaspoons ground cumin  
½ teaspoon cumin seeds  
1 teaspoon black mustard seeds  
2 tablespoons tomato paste  
2 cups red lentils, rinsed and drained  
2 cups vegetable stock  
1 litre water  
400g can chopped tomatoes  
3 baby eggplants, chopped coarsely  
4 hard boiled eggs, optional  
Salt and freshly ground black pepper

1. Heat oil in frypan on MIN/MED setting. Add onion and garlic and cook, stirring, for 2-3 minutes or until onion is soft.
2. Add dried spices and cook a further 1 minute, or until spices are fragrant. Stir through tomato paste and cook for 2 minutes.
3. Increase heat to MAX setting; add lentils, stock and water and bring mixture to the boil. Reduce heat to MIN/MED setting and cook, uncovered, stirring occasionally, until the mixture thickens slightly.
4. Add the tomatoes and eggplant and cook, covered, for 10 minutes. Remove lid and cook for a further 10 minutes or until dhal has thickened and the eggplant is soft.
5. Add whole peeled eggs and stir gently until heated through.
6. Season to taste.

## Penne Boscaiola

### Serves 4

6 rashers bacon  
200g sliced button mushrooms  
⅔ cup white wine  
300ml cream  
Salt and freshly ground black pepper  
500g penne  
shaved parmesan, to serve

1. Have a large pot of boiling water ready.
2. Remove rind from bacon and slice into 5mm pieces.
3. Heat frypan on MED/MAX setting. Cook bacon until golden. Add mushrooms and stir through.
4. Add wine and cook, stirring, until the wine has reduced by half. Add cream and cook, stirring occasionally, until the sauce has thickened slightly.
5. Cook pasta until just tender, drain and add to sauce and stir through. Season with salt and pepper. Serve immediately with shaved parmesan.

# Recipes

## Lamb Tagine

### Serves 4-6

2 tablespoons olive oil  
8 lamb shanks, fat trimmed  
1 large onion, sliced thinly  
2 cloves garlic, crushed  
1½ tablespoons Moroccan dried spice mix  
1 tablespoon tomato paste  
1 x 400g can chopped peeled tomatoes  
1 cup chicken stock  
1 cinnamon stick  
3 cardamom pods, cracked  
Salt and freshly ground black pepper  
1 x 400g tin chickpeas, drained and rinsed  
1 large sweet potato, peeled and chopped into 2 cm dice  
1 cup fresh coriander, roughly chopped  
Cous cous, to serve

1. Heat oil in frypan on MED/MAX setting. Cook lamb shanks in batches for 3-5 minutes or until evenly brown all over; remove from heat.
2. Reduce heat to MED setting, and add onion and garlic to frypan and cook for 5 minutes, or until onion has softened and coloured. Add spice mix and cook until fragrant. Stir through tomato paste.
3. Return the lamb shanks to the frypan with tomatoes, stock, cinnamon, and cardamom. Cover and cook, on MIN/MED setting, turning and stirring occasionally for 2 hours. After 2 hours add chickpeas, sweet potato and cook, covered until the sweet potato is tender.
4. Season to taste with salt and pepper. Stir through chopped coriander, serve with cous cous.

## Matt's Meatballs

### Serves 6-8

1.2kg lean beef mince  
⅔ cup packaged breadcrumbs  
3 eggs  
2 tablespoons Worcestershire sauce  
2 teaspoons dried sweet basil  
1 teaspoon dried oregano  
2 cloves garlic, crushed  
Salt and freshly ground black pepper  
2 tablespoons olive oil

### Sauce

1 onion, sliced  
2 cloves garlic, crushed  
2 tablespoons tomato paste  
1 green capsicum, sliced  
1 red capsicum, sliced  
1 litre ketchup

1. Combine meatball ingredients; roll into balls slightly smaller than golf balls.
2. Heat half of the oil in frypan on MED setting. Cook meatballs, in batches, until browned all over. Remove from pan.
3. Heat remaining oil in frypan on MED setting; cook onions and garlic, stirring, until the onions are translucent. Add tomato paste and cook for about 1-2 minutes or until fragrant. Add capsicums; cook, stirring occasionally, until tender. Add sauce and cook for 10 minutes. Reduce heat to MIN/MED setting; add meatballs and cook, covered, for a further 10 minutes or until the meatballs are cooked through.
4. Serve in long crusty bread rolls as a sub sandwich or with pasta.

# Recipes

## Lamb Rack with Garlic

### Serves 4 and Parmesan Crust

2 x 400g lamb rack roast, French trimmed  
4 slices of day old bread, crust removed  
2 cloves garlic, chopped  
2 tablespoons grated fresh parmesan  
1 tablespoon chopped fresh rosemary  
2 tablespoons seeded mustard  
Olive oil spray  
Salt and freshly ground black pepper  
Mashed potatoes, to serve

1. Preheat frypan on MED/MAX setting.
2. Place lamb racks on a chopping board, having the bones interlocked in the middle.
3. Combine bread, garlic, parmesan and rosemary in a food processor. Process until mixture resembles fine breadcrumbs.
4. Spread mustard evenly over the outside of the cutlets flesh.
5. Press the bread mixture over the mustard and spray well with olive oil spray.
6. Place lamb racks in frypan, reduce heat to MIN/MED setting and cook, covered, for about 35 minutes or until cooked as desired. Remove from frypan and cover with foil. Allow to rest 5-10 minutes.
7. Cut lamb into individual cutlets and serve with mashed potatoes.

**Tip:** Recipe can be doubled to serve 8.

## Roast Chicken with Stuffing

### Serves 4

1.2kg whole fresh chicken  
Salt and freshly ground black pepper

### Stuffing

1 onion, chopped finely  
2 teaspoons olive oil  
3 cups fresh bread crumbs  
30g butter, softened  
1 teaspoon grated lemon rind  
2 tablespoons chopped fresh parsley  
2 teaspoons chopped fresh thyme

1. Wash and clean chicken thoroughly. Pat dry with paper towelling.
2. To make stuffing, cook onion in oil until softened. Add to remaining stuffing ingredients and mix well.
3. Place the stuffing inside the cavity of the chicken. Tuck the wings back and tie the base of the chicken with cooking string so that the legs are crossed and securely positioned.
4. Preheat frypan on MED/MAX setting. Brush chicken with a little oil and salt and pepper.
5. Brown chicken on all sides; reduce heat to MED setting and cook, covered, for about 1½ hours or until cooked through.

**Tip:** If cooking roast vegetables, place in frypan  $\frac{3}{4}$  to 1 hour before the end of cooking.

# Recipes

## Roast Lamb

### Serves 4-6

- 1 leg lamb
  - 4-6 garlic cloves, sliced
  - 3-4 sprigs fresh rosemary, snipped into small pieces
  - 2 tablespoons olive oil
  - Salt and freshly ground black pepper
  - 6 small picking onions
  - 400g pumpkin, cut into chunks
  - ½ bunch baby carrots, trimmed
  - 2 potatoes, peeled, chopped
  - 1 sweet potato, peeled and thickly sliced
1. Using a small sharp knife, pierce the lamb all over, making indentations about 2cm deep. Push a piece of garlic into each slit and a small piece of rosemary. The rosemary should be poking out slightly.
  2. Heat frypan to MAX setting. Add oil and brown lamb all over. Season with salt and pepper; add onions to pan. Reduce heat to MED setting. Cook lamb, covered, for about 1 hour and 15 minutes.
  3. Add vegetables to pan and cook for a further 25 minutes. Remove lamb and allow to rest, covered, until the vegetables are cooked as desired.

## Mustard Seed Potatoes

### Serves 8

- 1.5kg baby new potatoes
  - 2 tablespoons extra virgin olive oil
  - 2 tablespoons black mustard seeds
  - 1-2 teaspoons sea salt flakes
1. Place potatoes into frypan and pour enough water in to cover. Cook potatoes, covered, on MAX setting until tender. Drain well for 10 minutes.
  2. Heat frypan on MED/MAX setting, add oil, potatoes, mustard seeds and salt; stir to coat. Place lid on potatoes and cook, stirring occasionally, until the potatoes are golden.
- Tip:** Keep the lid on during cooking as the mustard seeds pop!

# Recipes

## Individual Sticky Date Puddings

### Serves 8

200g coarsely chopped dried dates  
1 teaspoon bicarbonate soda  
1¼ cups boiling water  
60ml olive oil  
1 cup firmly packed brown sugar  
1 cup self raising flour  
¼ teaspoon mixed spice  
2 eggs

### Butterscotch sauce

160g butter  
⅔ cup firmly packed brown sugar  
1 cup (250ml) thickened cream

1. Preheat frypan on MIN/MED setting with the lid on. Grease 8 individual 1-cup capacity metal moulds.
2. Place dates, soda and boiling water into a blender or food processor. Place lid on and allow the mixture to stand for 5 minutes.
3. Add oil and sugar and pulse 3 times.
4. Add remaining ingredients and pulse mixture until just combined. Scrape down sides of bowl if necessary. Do not over process.
5. Pour mixture into prepared moulds. Place moulds in frypan and carefully pour enough boiling water to come half way up the sides of the moulds. Cook for about 25 minutes or until cooked when tested with a wooden skewer. Carefully remove from frypan; stand for 5 minutes before turning out onto a wire rack.
6. Serve pudding with butterscotch sauce. To make sauce, heat all ingredients in a small saucepan over a low heat until combined.

**Tip:** Puddings can be made in advance and then rewarmed in a microwave.

## Caramelised Bananas with Hot Chocolate Sauce and Whipped Cream

### Serves 4

4 large bananas  
¼ cup firmly packed brown sugar  
1 teaspoon cinnamon  
Whipped cream, to serve

### Hot chocolate sauce

100g dark chocolate, chopped  
30g white marshmallows, chopped  
150ml thickened cream

1. Preheat frypan on MIN/MED setting.
2. Cut bananas in half lengthways, leaving the skin on. Sprinkle the combined sugar and cinnamon over the cut bananas. Press gently into the banana.
3. Place bananas, cut side down and cook, uncovered, for about 6 minutes or until the sugar has caramelised and the banana has softened. Serve bananas with hot chocolate sauce and whipped cream.
4. To make the hot chocolate sauce, combine all ingredients in a small saucepan and cook, stirring, over a low heat, until melted.

# Recipes

## Spiced Rhubarb and Berry Compote

### Serves 4-6

- 2 bunches of rhubarb, cut into 2cm pieces
- 500g frozen mixed berries
- $\frac{3}{4}$  cup sugar
- 1 cinnamon stick
- 3 whole cloves
- 1 teaspoon grated orange rind

1. Combine all ingredients into the frypan. Cook, stirring gently, on MED/MAX setting until the sugar dissolves. Cover and cook on MED setting for about 15 minutes or until the rhubarb is tender.
2. Serve hot with ice cream, custard or with your favourite pudding.

## Crème Caramel

### Serves 6

- 1 cup caster sugar
- $\frac{1}{2}$  cup water
- $\frac{1}{3}$  cup caster sugar, extra
- 3 eggs
- 2 egg yolks
- 250ml cream
- 250ml milk
- 1 vanilla bean, seeds scraped

1. Combine sugar and water in a small saucepan. Stir over a low heat until the sugar has dissolved. Increase heat; boil without stirring, until the toffee turns a golden colour.
2. Remove from heat, once the bubbles have subsided, pour into 6 individual 1-cup capacity metal moulds. Allow to cool.
3. Beat eggs and extra sugar until light and creamy.
4. Heat milk, cream, vanilla bean and seeds until almost boiling. Whisk hot milk into egg mixture. Pour mixture through a strainer.
5. Pour mixture into moulds. Place moulds into frypan. Pour enough boiling hot water to come halfway up the sides of the moulds.
6. Cook, covered, on MED setting for about 15 minutes or until the custard has set.

**Note:** Be careful when removing lid to check custard that no water from the lid goes into the moulds.

# Troubleshooting

Problem	Potential Cause	Solution
<b>Overcooked / Undercooked Foods</b>	<ul style="list-style-type: none"> <li>• Incorrect temperature</li> </ul>	<ul style="list-style-type: none"> <li>• You may have to adjust the time and temperature to desired taste. Refer to "Temperature Setting Guide" section.</li> </ul>
<b>Burning Smell</b>	<ul style="list-style-type: none"> <li>• The temperature on your control probe is too high. Adjust temperature accordingly.</li> </ul>	<ul style="list-style-type: none"> <li>• Refer to "Temperature Setting Guide" section.</li> </ul>
<b>Heating elements do not stay ON</b>	<ul style="list-style-type: none"> <li>• Heating elements will cycle ON and OFF to maintain proper heat</li> </ul>	<ul style="list-style-type: none"> <li>• The thermostat light on the control probe indicates the temperature at which the dial is set. The light will remain on until the set temperature has been reached and then will cycle on and off throughout the cooking. This will ensure that the frypan maintains the correct temperature. On the initial heating of the frypan , it is recommended that the temperature be allowed to cycle (the light cycling on and off) several times. This will help the cooking surface to adjust to a more accurate cooking temperature.</li> </ul>

# 12 Month Replacement Guarantee

This Sunbeam product is covered by a 12 month replacement or repair warranty, which is in addition to your rights under the Australian Consumer Law (if your product was purchased in Australia) or New Zealand Consumer Guarantees Act (if your product was purchased in New Zealand).

Upon receipt of your claim, Sunbeam will seek to resolve your difficulties or, if the product is defective, advise you on how to obtain a replacement or refund.

To assist us in managing warranty claims, we recommend you register your product as soon as practicable after purchase by creating a MySunbeam account on our website and uploading a copy of your original receipt.

In order to make a claim under our warranty, you must have the original proof of purchase documentation for the product and present it when requested (if not already uploaded to our website).

Should your product develop any defect within 12 months of purchase because of faulty materials or workmanship, we will replace or repair it, at our discretion, free of charge. A product presented for repair may be replaced by a refurbished product of the same type rather than being repaired. Refurbished parts may be used to repair the product.

Our replacement or repair warranty only applies where a defect arises as a result of faulty material or workmanship during the warranty period. Your warranty does not cover misuse or negligent handling (including damage caused by failing to use the product in accordance with this instruction booklet), accidental damage, or normal wear and tear.

Your warranty does not:

- cover freight or any other costs incurred in making a claim, consumable items, accessories that by their nature and limited lifespan require periodic renewal (such as filters and seals) or any consequential loss or damage; or
- cover damage caused by:
  - power surges, power dips, voltage supply problems, or use of the product on incorrect voltage;

- servicing or modification of the product other than by Sunbeam or an authorised Sunbeam service centre;
- use of the product with other accessories, attachments, product supplies, parts or devices that do not conform to Sunbeam specifications; or
- exposure of the product to abnormally corrosive conditions; or

- extend beyond 3 months if the product is used in commercial, industrial, educational or rental applications.

**The benefits given to you by our warranty are in addition to other rights and remedies under law in relation to the product.**

**In Australia our goods come with guarantees that cannot be excluded under the Australian Consumer Law. You are entitled to a replacement or refund for a major failure and for compensation for any other foreseeable loss or damage. You are also entitled to have the goods repaired or replaced if the goods fail to be of acceptable quality and the failure does not amount to a major failure.**

**Our goods also come with guarantees that cannot be excluded under the New Zealand Consumer Guarantees Act.**

If your warranty claim is not accepted, we will inform you and if requested to do so by you, repair the product provided you pay the usual charges for such repair. You will also be responsible for all freight and other costs.

Should your product require repair or service after the warranty period, contact your nearest Sunbeam service centre. For a complete list of Sunbeam's service centres, visit our website or call our customer service line for advice on 1300 881 861 in Australia, or 0800 786 232 in New Zealand.

Should you experience any difficulties with your product during the warranty period, please contact our customer service line for advice on 1300 881 861 in Australia, or 0800 786 232 in New Zealand.

## Australia

www.sunbeam.com.au  
1300 881 861  
Suite 1, Level 1,  
13 Lord Street,  
Botany NSW 2019  
Australia

## New Zealand

www.sunbeam.co.nz  
0800 786 232  
Level 6, Building 5,  
Central Park, 660-670  
Great South Road,  
Greenlane, Auckland  
New Zealand



## Need help with your appliance?

Contact our customer service team or visit our website for information and tips on getting the most from your appliance.

Australia | visit [www.sunbeam.com.au](http://www.sunbeam.com.au)  
phone 1300 881 861  
mail Suite 1, Level 1,  
13 Lord Street,  
Botany NSW 2019  
Australia

New Zealand | visit [www.sunbeam.co.nz](http://www.sunbeam.co.nz)  
phone 0800 786 232  
mail Level 6, Building 5, Central  
Park, 660–670 Great South  
Road, Greenlane, Auckland.

Newell Australia Pty Ltd | ABN 68 075 071 233

Sunbeam is a registered trade mark.

Made in China to Sunbeam's specification.

Due to minor changes in design or otherwise,

the product you buy may differ slightly from the one shown here.

Approved by the appropriate electrical regulatory authorities.

©Copyright Sunbeam 2021.

02/21

FPM4000DF\_21EM1 (ANZ)

GCDS-SUN-SL