

Sunbeam

Alinea DiamondForce 4L Air Fryer Alinea Digital DiamondForce 4L Air Fryer

User Guide

AFP4505BK

AFP4510BK



Contents

Sunbeam's Safety Precautions	1
Features of your Sunbeam Alinea DiamondForce Air Fryer (AFP4505BK)	2
Control Panel	3
Features of your Sunbeam Alinea DiamondForce Air Fryer (AFP4510BK)	4
Control Panel	5
Temperature Settings Guide	6
Usage Instructions	7
Cooking Functions and Presets	10
Care and Cleaning	11
Cooking Guide	12
Recipes	14
Troubleshooting	18

Important instructions – retain for future use.

تأكد من تفهم احتياطات السلامة المذكورة اعلاه

請務必理解上述的安全預防措施。

Assurez-vous que les précautions ci-dessus relatives à la sécurité sont bien comprises

Versichern Sie sich, dass die obenstehenden Sicherheitsmaßnahmen Verstanden werden

Βεβαιώστε πως οι παραπάνω προφυλάξεις ασφαλείας γίνονται κατανοητές

Pastikan bahwa tindakan-tindakan keselamatan seperti di atas dimengerti anda

Accertatevi che le suddette norme di sicurezza siano comprese a dovere

上記の注意事項をよくお読みになり、安全を御確認ください

Уверете се дека погоре споменатите мерки на претпазливост се добро разбрани

Asegúrese de que las precauciones de seguridad precedentes sean bien comprendidas

کاری بکنید کہ احتیاط‌های بالا حتماً درک بشوند

ต้องแน่ใจว่า ข้อควรระวังเรื่องความปลอดภัยข้างต้น เป็นที่เข้าใจกันดี

Yukarda belirtilen güvenlik önlemlerinin anlaşıldığından emin olunuz

Xin kiểm chắc rằng những biện pháp làm an toàn kể trên được hiểu rõ

Sunbeam's Safety Precautions

SAFETY PRECAUTIONS FOR YOUR ALINEA DIAMONDFORCE AIR FRYERS

- Use your air fryer at least 200mm away from walls and curtains, and do not use in confined spaces.
- Do not operate the air fryer when placed directly onto a bench top. Place a heat proof mat or chopping board underneath to protect the surface.
- Avoid placing your air fryer on top of stone/stone polymer composite benchtops as this type of benchtop can be susceptible to cracking under heat.
- Do not operate the unit on an inclined surface.
- Do not move or cover the unit whilst in operation.
- Do not immerse the base of the unit in water or any other liquid.
- Do not touch any metal surface of the unit whilst in use as it will be hot.
- Use oven mitts when supporting the base of the basket during basket removal when hot.
- Use only the supplied basket and tray inside the unit.
- Do not plug in or switch on the unit without having the basket inside the air fryer unit.
- Do not place food or liquid inside the unit. Only place inside the basket or top of the supplied tray.
- Do not operate the unit without food or liquid in the basket or supplied tray.
- Do not use the basket or tray on the stovetop, inside a microwave oven or inside an oven.

Sunbeam is very safety conscious when designing and manufacturing consumer products, but it is essential that the product user also exercise care when using an electrical appliance. Listed below are precautions which are essential for the safe use of an electrical appliance:

- Read carefully and save all the instructions provided with an appliance.
- Always turn the power off at the power outlet before you insert or remove a plug. Remove by grasping the plug - do not pull on the cord.
- Turn the power off and remove the plug when the appliance is not in use and before cleaning.
- Do not use your appliance with an extension cord unless this cord has been checked and tested by a qualified technician or service person.
- Always use your appliance from a power outlet of the voltage (A.C. only) marked on the appliance.
- This appliance is not intended for use by persons (including children) with reduced physical, sensory or mental capabilities, or lack of experience and knowledge, unless they have been given supervision or instruction concerning use of the appliance by a person responsible for their safety.
- Children should be supervised to ensure that they do not play with the appliance.
- The temperature of accessible surfaces may be high when the appliance is operating.
- Never leave an appliance unattended while in use.
- Do not use an appliance for any purpose other than its intended use.
- Do not place an appliance on or near a hot gas flame, electric element or on a heated oven.
- Do not place on top of any other appliance.
- Do not let the power cord of an appliance hang over the edge of a table or bench top or touch any hot surface.
- Do not operate any electrical appliance with a damaged cord or after the appliance has been damaged in any manner. If damage is suspected, return the appliance to the nearest Sunbeam Appointed Service Centre for examination, repair or adjustment.
- For additional protection, Sunbeam recommend the use of a residual current device (RCD) with a tripping current not exceeding 30mA in the electrical circuit supplying power to your appliances.
- Do not immerse the appliance in water or any other liquid unless recommended.
- Appliances are not intended to be operated by means of an external timer or separate remote control system.
- This appliance is intended to be used in household and similar applications such as: staff kitchen areas in shops, offices and other working environments; farm houses; by clients in hotels, motels and other residential type environments; bed and breakfast type environments.



**Hot Surface
Do Not Touch**

This symbol indicates, temperature of accessible surfaces may be high when the appliance is operating and for some time after use.

If you have any concerns regarding the performance and use of your appliance, please visit www.sunbeam.com.au or contact the Sunbeam Consumer Service Line.

Ensure the above safety precautions are understood.

Features of your Sunbeam Alinea DiamondForce Air Fryer

AFP4505BK

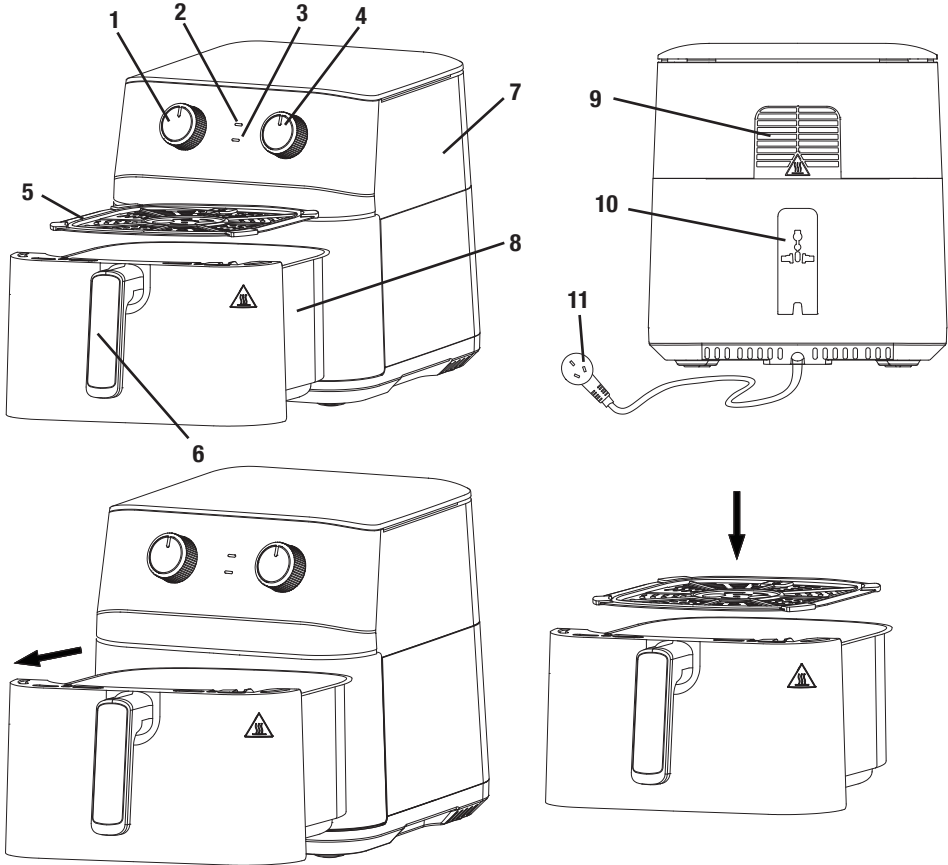

Parts

- 1. Temperature dial
- 2. Heating indicator light
- 3. Power indicator light
- 4. Timer dial
- 5. Air Fryer Tray
- 6. Handle
- 7. Main housing
- 8. Cooking drawer
- 9. Hot air outlet
- 10. Cord Wrap
- 11. Power Cord

Control Panel

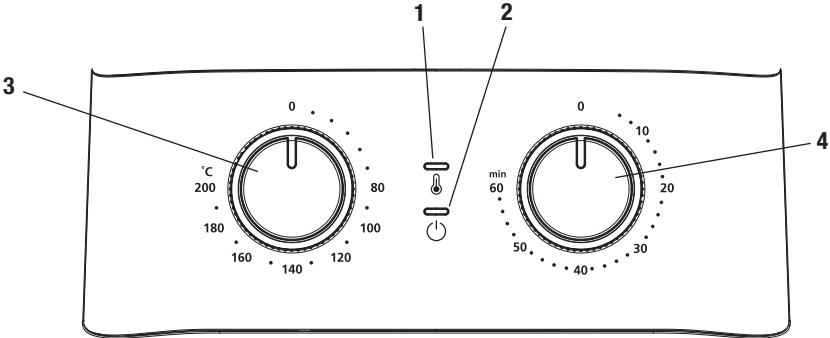

- 1. Heating indicator
- 2. Power Indicator
- 3. Temperature dial
- 4. Timer dial

Features of your Sunbeam Alinea DiamondForce Air Fryer

AFP4510BK

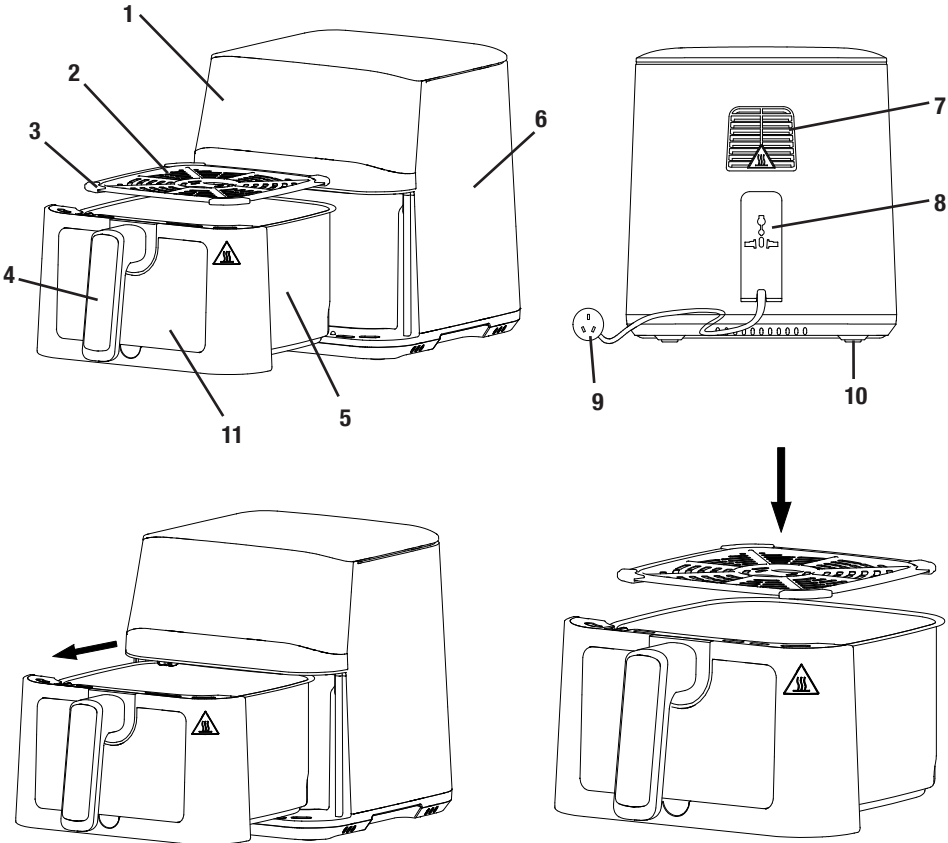

Parts

- 1. Control panel
- 2. Air Fryer Tray
- 3. Silicone pads
- 4. Handle
- 5. Cooking drawer

- 6. Main Housing
- 7. Hot air outlet
- 8. Cord wrap
- 9. Power cord
- 10. Non slip silicone feet
- 11. Removable window cover

Control Panel

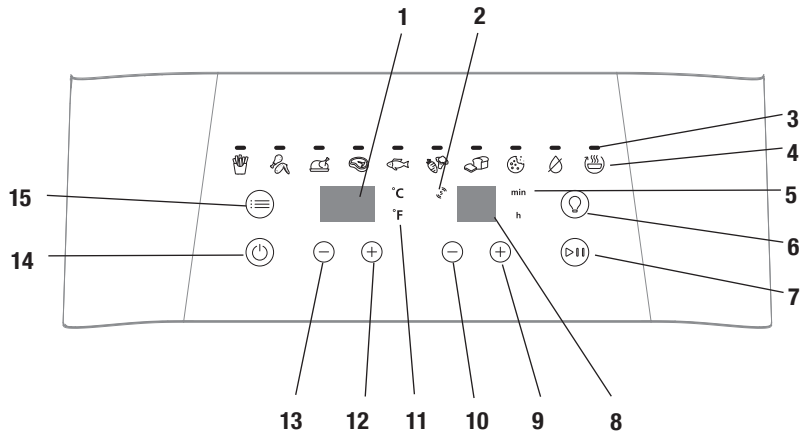











1. Temperature LED display
2. Shake indicator (lights up halfway through the cooking cycle)
3. Cooking Function indicator
4. Cooking Function icons
5. Time unit indicator
6. Light ON/OFF button
7. Start/Pause button
8. Time LED Display
9. Increase Time Button
10. Decrease Time Button
11. Temperature unit indicator
12. Increase temperature button
13. Decrease temperature button
14. Power button
15. Menu select button

Temperature Settings Guide

For AFP4510BK Only

This table provide the default time and temperature for each Cooking Function and/or Air Fry Preset. These can be adjusted using the Temperature and Timer Setting buttons.

Function	Icon	Capacity (4L)	Temperature	Time (min.)	Note
Fries		400g	200 °C	20 - 25 min	Shake halfway through the cooking process.
Chicken Wings		Approx 6 pc	200 °C	22 min - 30 min	Flip half way through the cooking process.
Whole Chicken		5lbs	175 °C	75 min	Flip half way through cooking process.
Steak		190g	200 °C	12 min - 15 min	Pre-heat air fryer for 3 min. Flip half way through the cooking process.
Fish		330g fillet, 7-9 min	175 °C	12 min	Preheat for 2 minutes before placing fish inside cooking basket.
Fresh Vegetables mix.		340g	170 °C	9-12 min	Coat with oil and season. Shake halfway through cooking process.
Bake		1 loaf of bread (17 cm long)	175 °C	25 min	Cover the bread in aluminum foil and cook for 25 min. For more crust, remove foil at the end and cook for 5 min.
Dessert		4 cookies	160 °C	12 min	Place aluminum foil on the cooking tray, place cookies on top of foil.
Dehydrate		1 layer of thinly sliced bananas or strawberries	60 °C	6h	Place thinly sliced bananas on the cooking tray making one layer of food, try not to overlay pieces on top of each other.
Reheat			190 °C	3 min	

Please note that due to the variations in thickness and size of foods being cooked, cooking results may vary. Always ensure that the food is thoroughly cooked before consuming.

Usage Instructions

Before First Use

Before using your Air Fryer for the first time, unpack the appliance and remove all packaging, promotional materials and stickers from the product. Remove any plastic or cardboard from inside the cooking drawer. Remove all printed documents.

Wash the air fryer tray and cooking drawer in warm soapy water using a mild household detergent. Rinse thoroughly and dry.

Preparing Your Air Fryer

1. Place on a flat, level, heat-resistant surface.
2. To open the unit, pull the handle towards you.

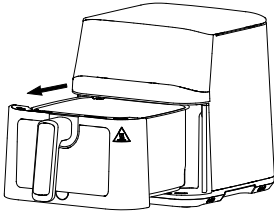

3. Ensure the air fryer tray is placed inside the base of the cooking drawer and pushed down to the bottom of the cooking drawer. Place your desired food inside the cooking drawer.

DiamondForce™ non-stick air fryer tray

The air fryer tray features the DiamondForce™ coating advantage with advanced non-stick performance. This unique diamond infused non-stick coating provides superior food release, requiring little to no oil when air frying food and easy wipe clean up.

Caution: Do not touch the cooking drawer and tray during and after use, as they get very hot.

4. Slide the cooking drawer back into the air fryer. Never use the air fryer without the cooking drawer in it.

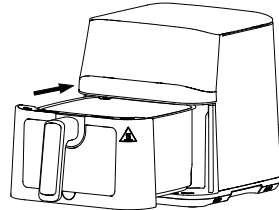

Usage Instructions

For AFP4505BK

Cooking in Your Air Fryer:

1. Plug the cord into 230-240VAC power outlet.
2. Turn the temperature control dial to the required temperature.
3. To switch the air fryer on, turn the time control dial to the desired cooking time. The power and heating lights will illuminate.

NOTE: For cooking times under 10 minutes, you must turn the dial past the 10 minute mark to activate timer and then turn anti-clockwise to the desired time.

NOTE: For best results, add an additional 3-5 minutes for preheat before placing food in the air fryer.

4. Use the handle to gently pull the cooking drawer from the air fryer. Ensure that the air fryer tray is properly in place then place food in the drawer. Replace the drawer back into the air fryer properly. If the drawer is not inserted properly, the appliance will not operate.
5. Some ingredients require shaking through the cooking process. Pull the handle and gently shake/stir the food. you can use heat-resistant plastic or wooden or silicone utensils. Slide the cooking drawer back into the air fryer to continue cooking.
NOTE: The removable air fryer tray may move out of place when shaking/ stirring food in the drawer. Ensure the air fryer tray is in the proper position before returning the drawer to the air fryer to continue cooking.
6. When you hear the timer bell, the set cooking time has finished. Pull the drawer out of the air fryer and place it on a heat resistant surface. Check if the

foods are ready. If not, simply put back into the air fryer and set the time for a few extra minutes.

7. When the food is ready, carefully pull the cooking drawer from the air fryer and empty food into serving bowl or plate. Be careful that the air fryer tray may come loose. For larger or more fragile items, use tongs to lift the food out of the drawer.

Note: Avoid using sharp or metal objects to prolong the life of your non-stick surface. Do not cut food inside the cooking drawer or air fryer tray. Do not leave utensils inside the cooking drawer or on top of the unit.

Note: When you pull the cooking drawer out of the unit, the air fryer will stop. Cooking will resume once the cooking drawer has been put back in and aligned back to the body of the air fryer.

Audible alert will sound once timer is done.

After cooking, carefully pull the cooking drawer out completely out of the unit and on to a stable, even, and heat resistant surface.

Caution: Do not turn the cooking drawer upside down as any excess oil that has collected in the bottom of the cooking drawer will leak onto the ingredients.

Caution: Oil left in the base of the cooking drawer may be hot.

Empty the cooking drawer into a bowl or onto a plate using heat resistant utensils.

Usage Instructions

For AFP4510BK

Cooking in Your Air Fryer:

1. Plug the cord into 230-240VAC power outlet and turn the power (⏻) on.
2. Once plugged in and the cooking drawer is properly placed in the main housing, the power light will be illuminated.
3. Select a cooking function or air fryer preset button.
4. The default temperature and time will be displayed (see page 6). Adjust temperature or time if required.
5. Press the Start/Stop button. The air fryer will begin to heat up and the time will start counting down.
6. Some ingredients require shaking through the cooking process. The unit will beep 3 times halfway through the cooking process to remind you to do this. Pull the handle and gently shake/stir the food. you can use heat-resistant plastic or wooden or silicone utensils. Slide the cooking drawer back into the air fryer to continue cooking.

Note: Avoid using sharp or metal objects to prolong the life of your non-stick surface. Do not cut food inside the cooking drawer or air fryer tray. Do not leave utensils inside the cooking drawer or on top of the unit.

Note: When you pull the cooking drawer out of the unit, the air fryer will stop, display will turn off and time will pause. Cooking will resume once the cooking drawer has been put back in and aligned back to the body of the air fryer. Your setting will only reset when the cooking drawer has not been put back in after 10 minutes.

Audible alert will sound once timer is done and "END 00" will display on the control panel.

After cooking, carefully pull the cooking drawer out completely out of the unit and on to a stable, even, and heat resistant surface.

Caution: Do not turn the cooking drawer upside down as any excess oil that has collected in the bottom of the cooking drawer will leak onto the ingredients.

Caution: Oil left in the base of the cooking drawer may be hot.

Empty the cooking drawer into a bowl or onto a plate using heat resistant utensils.

Cooking Functions and Presets

AFP4510BK

Manual Mode

This product allows you to adjust the temperature and time for air frying using the temp up/ down and time up/ down buttons.

Use these buttons when a recipe calls for a specific cooking time or to adjust based on food quantities.

Note: To quickly pause cooking cycle, pull the cooking drawer out. Alternatively, you can press Start/Stop button.

Food Presets

This product has 10 preset food programs that can be selected.

1. Choose from the 10 food presets: Fries, Wings, Whole Chicken, Steak, Fish, Vegetables, Bake, Dessert, Dehydrate or Warm. Temperature and time will automatically appear.
2. Adjust the temperature or time if required and then press Start/Stop button to start.

Note: When you pull the cooking drawer out of the unit, air fryer will stop, display will turn off and time will pause. Cooking will resume once the cooking drawer has been put back in and aligned back to the body of the air fryer. Your setting will only reset when the cooking drawer has not been put back in after 10 minutes.

Note: The unit will beep 3 times halfway through the cooking process as a reminder to turn food or shake the cooking drawer for even cooking.

Care and Cleaning

Avoid using sharp or metal objects to prolong the life of your cooking surface. Do not cut food inside the cooking drawer or tray. Do not leave utensils in contact inside the cooking drawer or on top of the unit.

To clean after use

Caution: Always unplug your air fryer and allow it to cool completely before cleaning it. NEVER immerse the MAIN body, power cord or plug in water or any other liquid.

Cooking Drawer and Air Fryer Tray

Empty the cooking drawer and tray frequently to avoid accumulation of crumbs and clean after each use.

The air fryer tray is dishwasher safe. Wash cooking basket and removable window cover in warm soapy water then rinse and dry.

The air fryer interior can be wiped with a damp cloth using warm, soapy water.

CAUTION: Do not immerse in water.

Using abrasive cleaners, scrubbing brushes and chemical cleaners will damage the unit.

Removable window cover (AFP4510BK)

1. The front cover of the window is removable for cleaning. To clean the window cover, make sure the unit is cool before handling. Place index finger in bottom cavity and pull back to remove as shown below. Clean with warm soapy water. Dry with a soft cloth and replace window.

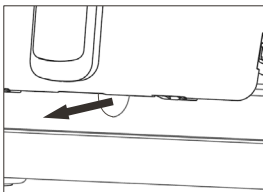

2. To replace the window cover: align the top tabs on the window cover with the corresponding slots (see image below), then gently push the bottom of the cover back in place.

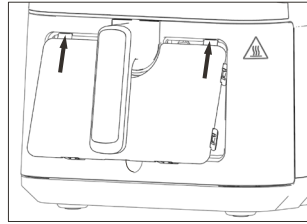

CAUTION: Do not use the air fryer without the cover in place as the glass will get hot.

DiamondForce™ non-stick air fryer tray

When cleaning DiamondForce™ non-stick air fryer tray, do not use metal (or other abrasive scourer). When the air fryer tray has cooled down, you may wipe using a paper towel to remove residue on the tray. Wash with warm soapy water using a mild household detergent.

Rinse thoroughly and dry the air fryer tray with a soft cloth before storing.

Cooking Guide

Guide to cooking popular foods in your air fryer

The table on the next page provides basic cooking guidelines for popular foods that can be cooked using the food presets (**for AFP4510BK**): Fries, Wings, Whole Chicken, Steak, Fish and Vegetables.

Please note that due to the variations in thickness and size of the foods being cooked some experimentation may be required for the best cooking results. Always ensure that the food is thoroughly cooked to food-safe temperature throughout before consuming.

When cooking fresh fries, keep oil quantities as low as possible for the healthiest results. However, if you feel the fries are a little pale and require further browning, increase the quantity of oil slightly.

Note: For crispier results it is recommended to shake the cooking drawer 2-4 times throughout the cooking cycle.

For larger quantities (1kg), increase cooking times and toss food more frequently.

Cooking Guide

Air Fryer Cooking Chart

Food	Weight	Function/ Preset	Time	Temperature	Shake/Turn half way through cooking	Oil
POTATOES						
Hand Cut Fries	700g - 800g	Fries	25 – 30 mins	180°C	Yes	1 tbsp
Hand Cut Fries	250g	Fries	12 – 15 mins	200°C	Yes	½ tbsp
Frozen Fries, (Thick Cut)	500g – 700g	Fries	20 – 25 mins	200°C	Yes	No
Frozen Fries, (Thick Cut)	250g	Fries	13 – 15 mins	200°C	Yes	No
Frozen Fries, (Thin Cut)	500g – 700g	Fries	18 – 20 mins	200°C	Yes	No
Frozen Fries, (Thin Cut)	250g	Fries	10 – 12 mins	200°C	Yes	No
Frozen Sweet Potato fries	500g	Fries	15 – 18 mins	200°C	Yes	No
Frozen Hash Browns	600g	Fries	18 – 20 mins	200°C	Yes	No
Fresh Jacket Potatoes	1kg (4)	Fries	60 mins	180°C	No	½ tbsp
MEAT/POULTRY/FISH						
Steak	250g (1)	Steak	10 – 15 mins	200°C	Yes	½ tbsp
Pork Chops	600g (3)	Steak	15 – 20 mins	180°C	Yes	1 tbsp
Beef Burgers	340g (2)	Steak	16 – 18 mins	180°C	Yes	½ tbsp
Whole Roast Chicken	1.8kg – 2.2kg	Whole Chicken	80 – 90 mins	170°C	No	1 tbsp
Whole Roast Chicken	1.3kg – 1.6kg	Whole Chicken	60 – 70 mins	170°C	No	1 tbsp
Chicken Wings	1 kg	Wings	30 – 35 mins	180°C	Yes	No
Salmon Fillet	480g (2)	Fish	12 – 15 mins	180°C	No	No
FROZEN FOODS						
Frozen Battered Fish	400g (2)	Fish	12 – 15 mins	180°C	Yes	No
Frozen Chicken Nuggets	400g	Fries	12 – 15 mins	180°C	Yes	No
Frozen Vegetable Burgers	450g (4)	Fries	15 – 20 mins	200°C	Yes	No
Frozen garlic bread slices	6 slices	Fries	6 – 8mins	180°C	Yes	No
VEGETABLES						
Frozen Onion Rings	400g	Fries	10 – 12 mins	180°C	Yes	No
Fresh Roasting Vegetables	800g	Vegetables	15 – 20 mins	180°C	Yes	1 tbsp
Fresh Steamed Vegetables	700g – 800g	Vegetables	15 – 20 mins	100°C	Yes	No
Fresh Steamed Corn Cobs	200g – 250g	Vegetables	8 – 10 mins	100°C	No	No
Tenderstem Broccoli	200g – 250g	Vegetables	5 – 7 mins	100°C	No	No

Recipes

All recipes have been specifically created and tested by the Sunbeam Test Kitchen for the Sunbeam Alinea Digital DiamondForce Air Fryers. We hope you enjoy using your Sunbeam Air Fryer.

The temperature and time in each recipe are a guide only and may require adjustment to suit various thickness and size of food being cooked and individual tastes. Always ensure that the food is thoroughly cooked before consuming.

Salt & Pepper Squid

350g squid, cut down the center, scored diagonally and cut into bite size pieces

For the batter

4 tablespoon potato flour, ½ cup extra
2 tablespoon corn flour
1 egg, beaten
1 tablespoon mirin
1 tablespoon fish sauce
½ teaspoon salt
½ teaspoon black pepper
Vegetable oil spray

For the spiced salt

2 teaspoon sea salt, ground
1 teaspoon white pepper
Coriander to garnish

1. SPICED SALT - heat a small frying pan over medium-high heat, add salt and stir for 30 seconds. Remove from heat. Transfer to a small mortar and pestle, add the pepper crush, mixing well.
2. In a separate bowl, combine all the batter ingredients. Place the squid into the batter, remove one piece at a time and dredge through the extra potato flour, place into air fryer. Repeat with remaining pieces. Spray the calamari well with vegetable oil.
3. Select FISH program, adjust TEMPERATURE to 200°C, TIME 15 minutes. Press start button (cook in batches if drawer is crowded).
4. After cooking, carefully remove from the cooking drawer using heat resistant utensils.
5. Garnish with coriander and sprinkle with spiced salt.

Zucchini Tater Tots

Serves 4

3 medium zucchinis, grated (about 5 cups)
2 large eggs, lightly beaten
½ cup shredded cheddar
½ cup grated Romano
1 teaspoon dried oregano
1 teaspoon dried thyme
2 garlic cloves, crushed
Sea salt
Freshly ground black pepper
Tomato Sauce, for serving

1. Place zucchini in a kitchen towel and squeeze all excess liquid out. Line the air fryer tray with baking paper.
2. In a large bowl, mix together zucchini, egg, cheddar, Romano, oregano, thyme, garlic, salt, and pepper.
3. Spoon about 1 tablespoon of mixture and roll it into a gnocchi shape with your hands. Place on the baking sheet. Select FRIES program, adjust TEMPERATURE 200°C, TIME 10 minutes. Press start button (cook in batches if drawer is crowded).
4. After cooking, carefully remove from the cooking drawer using heat resistant utensils and on to a serving plate or bowl. Serve with tomato sauce on the side.

Recipes

Kentucky Drumsticks

5 chicken drumsticks or thighs
½ cup buttermilk
1 eggs, beaten
1 cups flour
½ teaspoon salt
¼ teaspoon thyme
¼ teaspoon basil
¼ teaspoon oregano
½ teaspoon celery salt
½ teaspoon black pepper
½ teaspoon dried mustard
2 teaspoon paprika
1 teaspoon garlic salt
½ teaspoon ground ginger
1.5 teaspoon white pepper
Olive oil spray

1. Soak drumsticks in buttermilk for up to 24 hours.
2. Place the eggs in one bowl and the combined flour and spices in a second bowl.
3. Remove chicken one piece at a time from buttermilk, drain off excess.
4. Dredge each chicken leg in the flour, then the eggs, then the flour once again. Put the coated drumstick in the cooking drawer and repeat with remaining chicken. Spray with olive oil.
5. Select WINGS program and adjust TEMPERATURE 200°C, TIME 15 mins. Turn chicken over halfway through cooking process and spray further with olive oil. Spray with oil if there are any dry flour spots.
6. After cooking, carefully remove from the basket using heat resistant utensils.
7. Ensure that the chicken is thoroughly cooked before consuming. Time may vary depending on the size and thickness of the chicken.

Spring Rolls

12.5g mixed dried mushrooms, soaked in hot water for 30 minutes
12.5ml olive oil
12.5ml sesame oil
½ onion, finely diced
1 cloves garlic, minced
½ tablespoon fresh ginger, minced
¼ green chilli, de-seeded and diced
¼ leek julienned, matchstick shape
¼ carrot, peeled and grated
1 tablespoon soy sauce
4 sheets filo pastry, kept damp under a damp cloth
12.5g butter, melted
Sprig of coriander, chopped

1. Heat olive oil and sesame oil in a wok over a high heat. Add onions, garlic, ginger and chilli, stir-fry for 1 minute.
2. Add leeks and carrot, continue to stir fry for a further 1 minute, add the mushrooms and stir-fry for 30 seconds. Remove from heat and season with soy sauce.
3. Working quickly, brush the sheets of filo pastry with a little melted butter on a flat work surface. Place tablespoons of the vegetable filling in the lower centre of the filo pastry. Fold the edges in and over the filling and then roll up into a cigar shape, tucking the pastry around the filling tightly to secure.
4. Arrange on air fryer tray lined with parchment paper or lightly greased with nonstick cooking spray and air fry on FRIES program, TEMPERATURE 200°C, TIME 5 minutes, or until golden and crispy, turning halfway through.
5. After cooking, carefully remove from the cooking drawer using heat resistant utensils and arrange on a serving plate, garnish with coriander and serve immediately.

Recipes

Crispy Tofu & Asian Greens

Serves 2

225g firm tofu, drained, patted dry, and cut into 4 pieces

Marinade

¼ cup soy sauce

⅛ cup hot chili sauce, such as Sriracha or sambal oelek chili sauce

Half red chilli, halved, seeded if desired

¼ cup chopped fresh coriander leaves

3 garlic cloves, coarsely chopped

½ tablespoon coarsely chopped peeled fresh ginger

To toss

¼ cup corn flour

½ tablespoon Peanut oil

For assembling into the bowl

70g baby kale or spinach leaves

2 radishes, finely sliced

1 cups brown rice, cooked

1 carrots, shredded

50g soybeans

1 tablespoon extra-virgin olive oil

Shallots for garnish

Fine sea salt to taste

1. Sliced shallots (white and green parts), for garnish.
2. In a blender, combine the soy sauce, chili sauce, chili halves, coriander, garlic, and ginger, puree until smooth.
3. Arrange the tofu on a plate or baking sheet.
4. Coat the tofu on both sides with two-thirds of the chili mixture (reserve the rest for serving). Cover with plastic wrap and refrigerate for 1 hour to 6 hours.
5. Remove the tofu from the refrigerator and dip the tofu in the corn flour, tap off the excess.
6. Drizzle the peanut oil over the tofu and place into the cooking drawer. Select VEGETABLES program, TEMPERATURE 190°C and TIME 5 minutes. Press start button. Turn tofu over through the cooking process. Cook until golden.
7. After cooking, carefully remove from the cooking drawer using heat resistant utensils.
8. In a large bowl, toss the kale and radish with the olive oil and salt to taste. Add the tofu and toss.
9. Arrange in a bowl with the rice, carrots and soybeans. Serve hot, topped with sliced shallots and coriander leaves, drizzle with reserved marinade.

Recipes

Easy Wholegrain Bread

4 cups (520g) whole wheat flour*
1 packet (11g) instant yeast (~1tablespoon)*
½ tsp salt
2 tsp maple syrup*
2 cups (480ml) warm water
1 tablespoon water, extra for brushing
1 tablespoon seed variety of choice

1. Add all ingredients to the bowl of a mixer with dough hook attached.
2. Mix for 5 minutes on low speed.
3. Remove dough and place in greased, 18cm glass bowl. Cover with greased aluminum foil.
4. Place in the air fryer select DEHYDRATE program, adjust TEMPERATURE 27°C and TIME 30 minutes for first proofing stage.
5. Remove dough, punch down and knead for 3 minutes on floured board.
6. Place dough in greased 20cm round high sided cake pan. Cover with greased aluminum foil and place pan in air fryer. Select DEHYDRATE program, adjust TEMPERATURE 27°C and TIME 30 minutes.
7. Carefully remove aluminum covering using mitts, brush dough with a little water and sprinkle with sesame seeds.
8. Select BAKE program, adjust TEMPERATURE 170°C and TIME for 25 minutes.
9. Remove bread from cake pan and cool on wire rack.

Roasted Granola

3 cups rolled oats
¼ cup honey or maple syrup
¼ cup avocado oil
½ teaspoon salt
2 tablespoon brown sugar
¼ cup unsalted almonds
¼ cup unsalted cashews
¼ cup cashew butter
¼ cup chia seeds
¼ cup coconut flakes
¼ cup dried raisins
¼ cup chocolate chip morsels optional

1. Add first 8 ingredients into a bowl and mix well.
2. Cut a parchment paper to the size of the base of the cooking drawer. Cut a few small holes so that the hot air can circulate properly.
3. Add the rolled oats mixture and spread it out evenly.
4. Select the BAKE program and adjust TEMPERATURE 160°C, TIME 12 minutes. Press start button.
5. After 5 minutes of baking, pull out the handle and add seeds and coconut pieces (if using), stir the granola mixture.
6. Place back in to the air fryer and cook for another 5 minutes.
7. When you have 2 minutes left, reduce temperature to 150°C. Press the TEMPERATURE SETTING button and then adjust using the MINUS button.
8. Carefully transfer the granola mixture from the cooking drawer using heat resistant utensils, to a bowl. When completely cool, add the remaining ingredients.
9. Store in an air-tight glass container for about 3 weeks.

Troubleshooting

PROBLEM	POTENTIAL CAUSE	SOLUTION
Undercooked Foods	Too much food was placed in cooking basket	To ensure proper cooking, all food must be exposed to the air coming from the fan. Always arrange food in a single layer and allow enough space between food pieces so the air can go through. Shake or flip the food thoroughly to ensure even cooking.
	Incorrect time / temperature setting	Some pre-set times (for AFP4510BK) are intended for thawed foods (i.e. meat and fish) and they might not be enough to fully cook frozen pieces. Follow the cooking times guide to decide the time and temperature setting required.
Overcooked Foods	Incorrect time/temperature setting	Some pre-set times (for AFP4510BK) are intended for frozen items (i.e. Fries), Refer to the cooking times guide to decide the proper time and temperature setting for your condition.
Unit does not start	Cooking basket slightly open	As a safety measure, this air fryer will not function unless the cooking drawer is fully inserted into the unit. Make sure the cooking drawer is properly in place and fully inserted and (for AFP4510BK) press the Start/ Cancel button  .
	Start-up error	Verify unit is plugged in, (for AFP4510BK) no error code is shown on the display, a program is selected and press the start button, verify timer is counting down. If after verifying all these items the unit is still not working, contact customer service.
Burnt smell	First Use	It is recommended to heat your air fryer to 390°F / 200°C for approximately 15 minutes to eliminate any manufacturing residue that may remain after shipping.
	Food build-up	Clean your air fryer frequently, preferably after each use to avoid food and grease build up.
Screen not responding (AFP4510BK)	--	Unplug unit, wait 10 seconds and plug back in. Ensure that the protective film has been removed from the screen.

Troubleshooting

PROBLEM	POTENTIAL CAUSE	SOLUTION
Error code on display: E1 or E2 (AFP4510BK)	Start-up error	Unplug unit, wait 10 seconds and plug back in. If unit still does not work, unplug unit and contact customer service to provide error code.
Air fryer does not turn on	Removable drawer is not inserted properly.	Insert the removable drawer properly, ensuring it clicks into the closed position.
	Power cord is not plugged in.	Make sure power cord is plugged in and the outlet has power.
	Plastic film not removed from the screen (AFP4510BK).	Remove protective plastic film from the screen.
Food is not evenly cooked	Too much food in cooking drawer or food was not stirred during cooking.	Arrange food in a single layer. Stir food during cooking process.

12 Month Replacement Guarantee

This Sunbeam product is covered by a 12 month replacement or repair warranty, which is in addition to your rights under the Australian Consumer Law (if your product was purchased in Australia) or New Zealand Consumer Guarantees Act (if your product was purchased in New Zealand).

Upon receipt of your claim, Sunbeam will seek to resolve your difficulties or, if the product is defective, advise you on how to obtain a replacement or refund.

To assist us in managing warranty claims, we recommend you register your product as soon as practicable after purchase, on our Sunbeam website and uploading a copy of your original receipt. View the Support section of the Sunbeam website.

In order to make a claim under our warranty, you must have the original proof of purchase documentation for the product and present it when requested (if not already uploaded to our website).

Should your product develop any defect within 12 months of purchase because of faulty materials or workmanship, we will replace or repair it, at our discretion, free of charge. A product presented for repair may be replaced by a refurbished product of the same type rather than being repaired. Refurbished parts may be used to repair the product.

Our replacement or repair warranty only applies where a defect arises as a result of faulty material or workmanship during the warranty period. Your warranty does not cover misuse or negligent handling (including damage caused by failing to use the product in accordance with this instruction booklet), accidental damage, or normal wear and tear.

Your warranty does not:

- cover freight or any other costs incurred in making a claim, consumable items, accessories that by their nature and limited lifespan require periodic renewal (such as filters and seals) or any consequential loss or damage; or
- cover damage caused by:
 - power surges, power dips, voltage supply problems, or use of the product on incorrect voltage;

- servicing or modification of the product other than by Sunbeam or an authorised Sunbeam service centre;
- use of the product with other accessories, attachments, product supplies, parts or devices that do not conform to Sunbeam specifications; or
- exposure of the product to abnormally corrosive conditions; or

- extend beyond 3 months if the product is used in commercial, industrial, educational or rental applications.

The benefits given to you by our warranty are in addition to other rights and remedies under law in relation to the product.

In Australia our goods come with guarantees that cannot be excluded under the Australian Consumer Law. You are entitled to a replacement or refund for a major failure and for compensation for any other foreseeable loss or damage. You are also entitled to have the goods repaired or replaced if the goods fail to be of acceptable quality and the failure does not amount to a major failure.

Our goods also come with guarantees that cannot be excluded under the New Zealand Consumer Guarantees Act.

If your warranty claim is not accepted, we will inform you and if requested to do so by you, repair the product provided you pay the usual charges for such repair. You will also be responsible for all freight and other costs.

Should your product require repair or service after the warranty period, contact your nearest Sunbeam service centre. For a complete list of Sunbeam's service centres, visit our website or call our customer service line for advice on 1300 881 861 in Australia, or 0800 786 232 in New Zealand.

Should you experience any difficulties with your product during the warranty period, please contact our customer service line for advice on 1300 881 861 in Australia, or 0800 786 232 in New Zealand.

Australia

www.sunbeam.com.au
1300 881 861

New Zealand

www.sunbeam.co.nz
0800 786 232

Need help with your appliance?

Contact our customer service team or visit our website for information and tips on getting the most from your appliance.

Australia | visit www.sunbeam.com.au
phone 1300 881 861

New Zealand | visit www.sunbeam.co.nz
phone 0800 786 232

NEWELL AUSTRALIA PTY LTD. ABN 68 075 071 233

Sunbeam is a registered trade mark.

Made in China to Sunbeam's specification.

Due to minor changes in design or otherwise,

the product you buy may differ slightly from the one shown here.

Approved by the appropriate electrical regulatory authorities.

© Copyright Sunbeam 2024.

05/24