

*Sunbeam*

MASTER  
SERIES

SG3000

# Butler Turbo Garment Steamer

User Guide



# Contents

Sunbeam's Safety Precautions	1
Assembling your Sunbeam Garment Steamer	2
Features of your Sunbeam Garment Steamer	3
Using your Sunbeam Garment Steamer	4
Steam Setting Chart	5
Care and Cleaning	6
Troubleshooting Guide	8

## Important instructions – retain for future use.

تأكد من تفهم احتياطات السلامة المذكورة اعلاه

請務必理解上述的安全預防措施。

Assurez-vous que les précautions ci-dessus relatives à la sécurité sont bien comprises

Versichern Sie sich, dass die obenstehenden Sicherheitsmaßnahmen Verstanden werden

Βεβαιώστε πως οι παραπάνω προφυλάξεις ασφαλείας γίνονται κατανοητές

Pastikan bahwa tindakan-tindakan keselamatan seperti di atas dimengerti anda

Accertatevi che le suddette norme di sicurezza siano comprese a dovere

上記の注意事項をよくお読みになり、安全を御確認ください

Уверете се дека погоре споменатите мерки на претпазливост се добро разбрани

Asegúrese de que las precauciones de seguridad precedentes sean bien comprendidas

کاری بکنید کہ احتیاط‌های بالا حتماً درک بشوند

ต้องแน่ใจว่า ข้อควรระวังเรื่องความปลอดภัยข้างต้น

เป็นที่เข้าใจกันดี

Yukarda belirtilen güvenlik önlemlerinin anlaşıldığınızı emin olunuz

Xin kiểm chắc rằng những biện pháp làm an toàn kể trên được hiểu rõ

# Sunbeam's Safety Precautions

## SAFETY PRECAUTIONS FOR YOUR GARMENT STEAMER

- Do not leave a hot garment steamer within reach of children. If they come into contact with a hot garment steamer it could lead to serious burns.
  - Unplug the appliance during filling and cleaning.
  - Care should be taken when using the appliance due to the emission of steam.
  - The garment steamer must not be stored whilst it is plugged into the power outlet.
  - The On/Off button on the unit is for functional use only during operation, and is not intended to provide disconnection from the power outlet.
- Before storing the garment steamer after use, it must be unplugged from the power outlet.
  - The garment steamer takes approximately 2 hours to completely cool down. Allow the garment steamer to cool completely before storing.
  - Do not leave the garment steamer unattended while it is plugged into the power outlet.
  - This garment steamer features an "auto-off" function, which is an additional safety feature designed to disconnect power to the heating element if the garment steamer has run out of water.

**Sunbeam is very safety conscious when designing and manufacturing consumer products, but it is essential that the product user also exercise care when using an electrical appliance. Listed below are precautions which are essential for the safe use of an electrical appliance:**

- Read carefully and save all the instructions provided with an appliance.
  - Always turn the power off at the power outlet before you insert or remove a plug. Remove by grasping the plug - do not pull on the cord.
  - Turn the power off and remove the plug when the appliance is not in use and before cleaning.
  - Do not use your appliance with an extension cord unless this cord has been checked and tested by a qualified technician or service person.
  - Always use your appliance from a power outlet of the voltage (A.C. only) marked on the appliance.
  - This appliance is not intended for use by persons (including children) with reduced physical, sensory or mental capabilities, or lack of experience and knowledge, unless they have been given supervision or instruction concerning use of the appliance by a person Responsible for their safety.
  - Children should be supervised to ensure that they do not play with the appliance.
  - The temperature of accessible surfaces may be high when the appliance is operating.
  - Never leave an appliance unattended while in use.
- Do not use an appliance for any purpose other than its intended use.
  - Do not place an appliance on or near a hot gas flame, electric element or on a heated oven.
  - Do not place on top of any other appliance.
  - Do not let the power cord of an appliance hang over the edge of a table or bench top or touch any hot surface.
  - Do not operate any electrical appliance with a damaged cord or after the appliance has been damaged in any manner. If damage is suspected, return the appliance to the nearest Sunbeam Appointed Service Centre for examination, repair or adjustment.
  - For additional protection, Sunbeam recommends the use of a residual current device (RCD) with a tripping current not exceeding 30mA in the electrical circuit supplying power to your appliances.
  - Do not immerse the appliance in water or any other liquid unless recommended.
  - Appliances are not intended to be operated by means of an external timer or separate remote control system.
  - This appliance is intended to be used in household and similar applications such as: staff kitchen areas in shops, offices and other working environments; farm houses; by clients in hotels, motels and other residential type environments; bed and breakfast type environments.

If you have any concerns regarding the performance and use of your appliance, please visit [www.sunbeam.com.au](http://www.sunbeam.com.au) or contact the Sunbeam Consumer Service Line.

**Ensure the above safety precautions are understood.**

# Assembling your Sunbeam Garment Steamer

## The steam hose

- Screw the steam hose into the base. Screw tight.

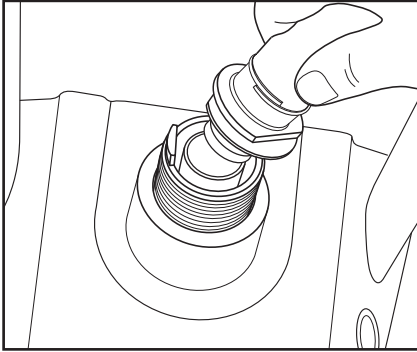

## The twin poles

- There are 2 poles. One end will have a small hole. Face this to the front of the unit and insert into the pole space on the base. Push the pole down firmly, and press the 'Push' button until you hear a click. The poles should be firm inside the base. Repeat with the other pole.

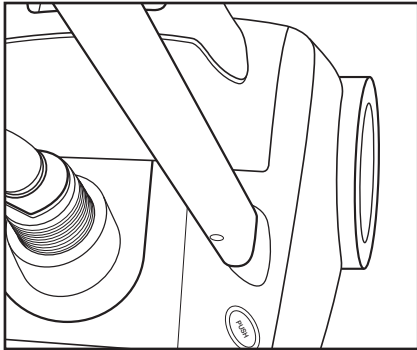

- The poles are telescopic for easy storage. There are 3 sections per pole. Starting at the bottom, open the clip on the first pole and pull upwards so that the telescopic poles inside can be drawn upwards. When it's at the maximum length, close the clip. Repeat with the other section of pole.

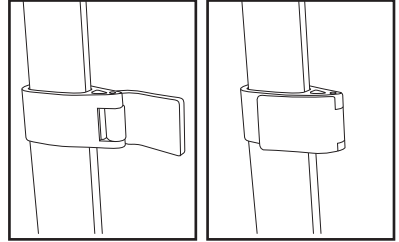

## Garment hanger

- Insert the garment hanger on top of the poles
- For easy storage, the hand steam guard rests on the garment hanger.

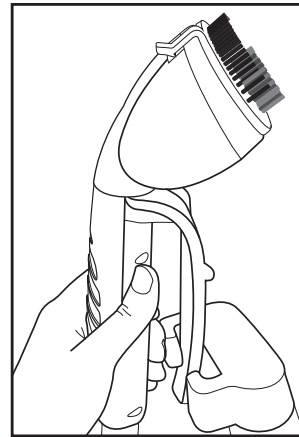

# Features of your Sunbeam Garment Steamer

## Hand Steam Guard

For comfort

## Rotating Garment hanger

Use the hanger, the clips or the coat hanger hook.

## 40 Sec Quick Start

Ready in 40 seconds, so you can start immediately.

## 2000W Fast Heat Up

Powerful 2000 watt element provides the fastest heat up, and higher steam performance.

## Steam hose

## Twin poles

For better garment support to make steaming even easier. Telescopic poles for easy storage.

## Large 3L removable tank

So you can steam for longer without having to refill.

## 5 Steam Settings

From 17g/min to 40g/min to best suit delicate synthetics to linen.

## Power On / Off button

## Tilt and Roll

## Safety Auto Standby

## Steam Brush

## Steam Cap

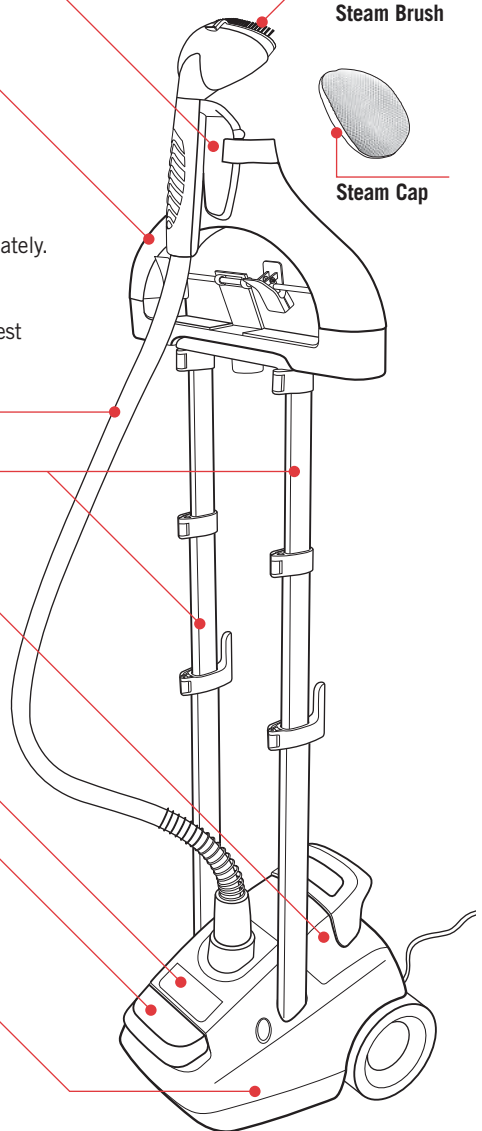

# Using your Garment Steamer

## Before first use

- Remove any adhesive stickers, plastic covers or cardboard sleeves from the garment steamer.
- Fill the water tank and then empty out the water. This will rinse out any foreign particles remaining in the water tank from the manufacturing process.

**NOTE:** When turned on for the first time, your new garment steamer may give off vapours for up to 10 minutes. This is due to the initial heating of the materials used. It is safe, and not detrimental to the performance of the garment steamer.

## Filling the tank with water

- Remove the tank from the unit and remove the tank lid. Then fill with water from the tap. Do not exceed the maximum water level indicator. Tighten the tank lid, then reinsert the water tank and ensure it's firmly in position.

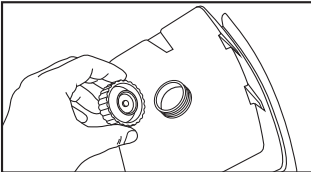

For best performance, we recommend the use of Sunbeam Demineralised Water as mineral deposits can build up in a garment steamer requiring the unit to be calc cleaned.

## Using your garment steamer

1. Insert the plug into a 230-240 volt power outlet and turn the power on.
2. Place the unit on the floor. The unit must be lower than the steam hose.
3. Push the power button to turn the unit on. The boiler will begin heating and the Steam light will illuminate.
4. Select the desired steam setting for your fabric. See Steam Settings list below. The Steam light will go out once the garment steamer has reached the selected temperature.
5. Before using the garment steamer on a garment, direct a shot of steam into the air to release any remaining condensation.
6. Ensure to always hold the steam hose using the hand steam guard for safety

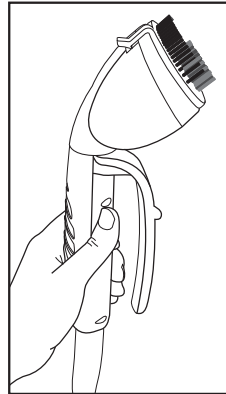

Steam light

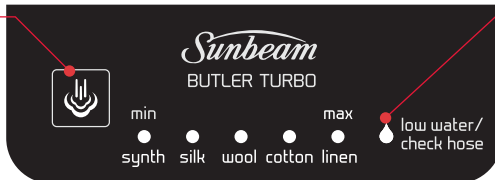

Water light

## Using your Garment Steamer continued

**NOTE:** The steam light illuminates to indicate the garment steamer is heating and goes out when it has reached temperature selected for your steam setting. The light will cycle on and off during use as the garment steamer maintains the selected temperature. Steam will begin around 40 seconds from switching the unit on, this will be longer if the tank water is cool.

**NOTE:** The steam will be irregular. This is normal. When the steam hose is bent, the passage of steam is restricted, and the steam may condense back into water. The water light may flash and the unit may beep as a reminder to straighten the hose before using again.

### Water light

When the unit detects an irregularity with the water, the Water light on the panel will flash, and the unit will beep as a reminder. This will occur for 2 reasons:

1. The water level in the tank is low. Simply refill the tank.
2. The steam hose is bent. Simply lift the steam hose head and straighten the hose, before using again. This will allow the condensation to flow back down to the tank.

### Safety Auto Standby

When the water is running out, the 'Water' light on the panel will flash, and the unit will beep to let you know to add more water. If there is no water in the tank, the unit will go into standby mode and stop heating. The unit will beep and the flashing light will continue until you add more water, or press the large on/off button to turn the unit off.

### Accessories

**Ensure the unit is switched off and cool before you add the accessories.**

- **The Steam Brush** simply clicks onto the steam head. It helps to open up the weave of fabrics to improve steam penetration. Steam in the direction of the nap or weave of the fabric. Do not use the Steam Cap with the Steam Brush.
- **The Steam Cap** is ideal to use most of the time as it assists in even steam dispersal, in preventing spotting and in protecting delicate fabrics (such as silk) from water droplets. Simply place over the steam head, but do not use with the Steam Brush. When finished, remove the Steam Cap to ensure it dries completely.

## Steam Setting Chart

Steam Setting	Fabric
1.	<b>Synthetics.</b> Nylon, Polyester, Rayon
2.	<b>Silk</b>
3.	<b>Wool,</b> Cotton Blends
4.	<b>Cotton,</b> Corduroy
5.	<b>Linen,</b> Jeans

# Care and Cleaning

## After each use

1. Turn the power off and remove the plug from the power outlet.
2. Allow the garment steamer to cool before storing.

## Storage

Empty the water tank before storage.

## Cleaning

To clean the exterior of your garment steamer, wipe over with a damp soft cloth and wipe dry.

**Caution:** Do not use harsh abrasives, chemical cleaners or solvents to clean the exterior of your garment steamer as these will damage the surface.

## Cleaning the steam holes from the steam hose head

To remove build up from the steam holes which may affect steam performance, use a cotton wool tip moistened in methylated spirits

## Calc Clean Instructions – using descaling tablets

Mineral deposits in tap water solidify when the water is heated and can build up in the unit of the garment steamer which can affect steam performance. It is important to regularly flush out the unit to maintain the best performance. We recommend calc cleaning every month. Use Ironing System descaling tablets. We recommend using Sunbeam Ironing System Descaling Tablets (SR0100).

1. Dissolve 1 x 6g tablet in 400ml of warm water (90 degrees is recommended) in a jug before use.
2. Turn the unit off and wait for it to cool completely (approx 2 hours).

**CAUTION:** The water in the unit and in the tank may be hot after use. Ensure to let the garment steamer cool down.

3. Pour out all remaining water from the water tank into the sink. Lift the base unit and pour out any remaining water from the unit into the sink. You may want to unscrew the steam hose for ease.
4. Then carefully pour the descaling solution into the base unit. Leave for 2 minutes. Gently shake the base unit back and forth to dislodge any scale build up inside the unit. Leave for 2 minutes.
5. Then pour out all remaining liquid from the unit into the sink.
6. Rinse by repeating process with 400ml of water (90 degrees is recommended), shake and empty the unit again. Repeat rinsing process at least 2 times.



## Care and Cleaning continued

### **Calc Clean instructions – using lemon juice**

Alternatively, if you do not have Sunbeam Ironing System Descaling Tablets, you can use lemon juice to remove the scale build up from inside the unit

1. Turn the unit off and wait for it to cool completely (approx 2 hours).
2. Pour out all remaining water from the water tank into the sink. Lift the unit and pour out any remaining water from the unit into the sink. You may want to unscrew the steam hose for ease.
3. In a small jug, add 3 tbs lemon juice to 400ml of warm water (90 degrees is recommended) and stir to mix.
4. Then carefully pour the descaling solution into the base unit. Leave for 2 minutes. Gently shake the base unit back and forth to dislodge any scale build up inside the unit. Leave for 10 minutes. Shake again.
5. Then pour out all remaining liquid from the unit into the sink.
6. Rinse by repeating process with 400ml of water (90 degrees is recommended), shake and empty the unit again. Repeat rinsing process at least 2 times.

# Troubleshooting Guide

Problem	Possible Reason	Solution
<p><b>Water Light</b></p> <p>When the Butler Turbo detects an irregularity with the water, the water light on the panel will flash, and the unit will beep as a reminder. This will occur for 2 reasons:</p>	<p>The water level in the tank is low.</p>	<p>Simply refill the tank.</p>
	<p>The steam hose is bent, so steam condenses back into water and will flow down into the tank.</p>	<p>Please straighten the hose.</p>
<p>Water is spitting from the steam hose.</p>	<p>The unit has been left and water residue has built up in the steam hose</p>	<p>Ensure the unit is on the floor. Wait for the unit to reach temperature so steam can build.</p>
	<p>The garment steamer unit is not on the floor, and/ or the steam hose is bent and steam is condensing in the steam hose. The steam hose needs to be straight and higher than the unit, so steam can rise up the steam hose.</p>	<p>Lift the steam hose head and straighten the hose. This will allow the condensation to flow back down to the unit.</p>
<p>There is some spotting on my garments</p>	<p>The unit needs a calc clean</p>	<p>Follow the Care Instructions on page 6 and calc clean your machine.</p>

# 24 Month Replacement Guarantee

This Sunbeam product is covered by a 24 month replacement or repair warranty, which is in addition to your rights under the Australian Consumer Law (if your product was purchased in Australia) or New Zealand Consumer Guarantees Act (if your product was purchased in New Zealand).

Upon receipt of your claim, Sunbeam will seek to resolve your difficulties or, if the product is defective, advise you on how to obtain a replacement or refund.

To assist us in managing warranty claims, we recommend you register your product as soon as practicable after purchase by creating a MySunbeam account on our website and uploading a copy of your original receipt.

In order to make a claim under our warranty, you must have the original proof of purchase documentation for the product and present it when requested (if not already uploaded to our website).

Should your product develop any defect within 24 months of purchase because of faulty materials or workmanship, we will replace or repair it, at our discretion, free of charge. A product presented for repair may be replaced by a refurbished product of the same type rather than being repaired. Refurbished parts may be used to repair the product.

Our replacement or repair warranty only applies where a defect arises as a result of faulty material or workmanship during the warranty period. Your warranty does not cover misuse or negligent handling (including damage caused by failing to use the product in accordance with this instruction booklet), accidental damage, or normal wear and tear.

Your warranty does not:

- cover freight or any other costs incurred in making a claim, consumable items, accessories that by their nature and limited lifespan require periodic renewal (such as filters and seals) or any consequential loss or damage; or
- cover damage caused by:
  - power surges, power dips, voltage supply problems, or use of the product on incorrect voltage;

- servicing or modification of the product other than by Sunbeam or an authorised Sunbeam service centre;
- use of the product with other accessories, attachments, product supplies, parts or devices that do not conform to Sunbeam specifications; or
- exposure of the product to abnormally corrosive conditions; or

- extend beyond 3 months if the product is used in commercial, industrial, educational or rental applications.

The benefits given to you by our warranty are in addition to other rights and remedies under law in relation to the product.

In Australia our goods come with guarantees that cannot be excluded under the Australian Consumer Law. You are entitled to a replacement or refund for a major failure and for compensation for any other foreseeable loss or damage. You are also entitled to have the goods repaired or replaced if the goods fail to be of acceptable quality and the failure does not amount to a major failure.

Our goods also come with guarantees that cannot be excluded under the New Zealand Consumer Guarantees Act.

If your warranty claim is not accepted, we will inform you and if requested to do so by you, repair the product provided you pay the usual charges for such repair. You will also be responsible for all freight and other costs.

Should your product require repair or service after the warranty period, contact your nearest Sunbeam service centre. For a complete list of Sunbeam's service centres, visit our website or call our customer service line for advice on 1300 881 861 in Australia, or 0800 786 232 in New Zealand.

Should you experience any difficulties with your product during the warranty period, please contact our customer service line for advice on 1300 881 861 in Australia, or 0800 786 232 in New Zealand.

## Australia

[www.sunbeam.com.au](http://www.sunbeam.com.au)  
1300 881 861  
Units 5 & 6,  
13 Lord Street,  
Botany NSW 2019  
Australia

## New Zealand

[www.sunbeam.com.nz](http://www.sunbeam.com.nz)  
0800 786 232  
Unit 3, Building D,  
26 Vestey Drive,  
Mt Wellington  
Auckland  
New Zealand

## Need help with your appliance?

Contact our customer service team or visit our website for information and tips on getting the most from your appliance.

Australia | visit [www.sunbeam.com.au](http://www.sunbeam.com.au)  
phone 1300 881 861  
mail Units 5 & 6, 13 Lord Street,  
Botany NSW 2019 Australia.

New Zealand | visit [www.sunbeam.co.nz](http://www.sunbeam.co.nz)  
phone 0800 786 232  
mail Level 6, Building 5, Central Park,  
600-670 Great South Road,  
Greenlane, Auckland, New Zealand.

Sunbeam Corporation Limited | ABN 45 000 006 771  
Sunbeam Corporation is a division of GUD Holdings Limited.

Sunbeam is a registered trade mark.

Sunbeam Butler Turbo is a trademark of Sunbeam Corporation.

Made in China to Sunbeam's specification.  
Due to minor changes in design or otherwise,  
the product you buy may differ slightly from the one shown here.  
Approved by the appropriate electrical regulatory authorities.

©Sunbeam Corporation Limited 2015.