

Sunbeam

Stainless Deep Fryer

4.0 litre cool-zone deep fryer
in brushed stainless steel

Instruction/Recipe Booklet

DF6300

Please read these instructions carefully
and retain for future reference.



Contents

Sunbeam's Safety Precautions	3
Features of your Sunbeam Stainless Deep Fryer	4
Using your Sunbeam Stainless Deep Fryer	6
Hints for perfect frying	8
Frying times and temperatures	9
Care and Cleaning	11
The Perfect Chip	13
Recipes	14
Troubleshooting	26

تأكد من تفهم احتياطات السلامة المذكورة اعلاه

請務必理解上述的安全預防措施。

Assurez-vous que les précautions ci-dessus relatives à la sécurité sont bien comprises

Versichern Sie sich, dass die obenstehenden Sicherheitsmaßnahmen verstanden werden

Βεβαιώνετε πως οι παραπάνω προφυλάξεις ασφαλείας γίνονται κατανοητές

Pastikan bahwa tindakan-tindakan keselamatan seperti di atas dimengerti anda

Accertatevi che le suddette norme di sicurezza siano comprese a dovere

上記の注意事項をよくお読みになり、安全を御確認ください

Уверете се дека погоре споменатите мерки на претпазливост се добро разбрани

Asegúrese de que las precauciones de seguridad precedentes sean bien comprendidas

کاری بکنید کہ احتیاطهای بالا حتماً درک بشوند

ต้องแน่ใจว่า ข้อควรระวังเรื่องความปลอดภัยข้างต้น เป็นที่เข้าใจกันดี

Yukarda belirtilen güvenlik önlemlerinin anlaşılığundan emin olunuz

Xin kiểm chắc rằng những biện pháp làm an toàn kể trên được hiểu rõ

Sunbeam's Safety Precautions

SAFETY PRECAUTIONS FOR YOUR DEEP FRYER.

- Before use always ensure that the internal tank is positioned correctly in the fryer body. ie the max/min level should be on the left of the fryer.
- Never connect the fryer to the electricity supply without placing oil in the tank first.
- If using solid fat, remove the lid and the basket, cut the fat into pieces and place them directly into the tank. Do not melt solid fat in the frying basket as it may damage the appliance.
- Never operate the fryer with oil level below the minimum mark or above the maximum mark.
- Do not touch any metal surfaces of the product while it is in use as they will be hot.
- Remove excess moisture and ice particles from food before deep frying.
- Excessive moisture in oil, can cause turbulence and could lead to overflowing.
- Check oil levels are correct before and during deep frying.
- Be careful when lifting lid whilst oil is heating up. Steam can result in serious burns. Never place face over deep fryer.
- Remove lid whilst food is in fryer. A closed lid can cause water condensation, and oil can splatter.
- Never decant oil from deep fryer while still hot.
- Do not move deep fryer once it is in use.
- Only use the oils recommended in this instruction booklet.

Sunbeam is very safety conscious when designing and manufacturing consumer products, but it is essential that the product user also exercise care when using an electrical appliance. Listed below are precautions which are essential for the safe use of an electrical appliance:

- Read carefully and save all the instructions provided with an appliance.
- Always turn the power off at the power outlet before you insert or remove a plug. Remove by grasping the plug - do not pull on the cord.
- Turn the power off and remove the plug when the appliance is not in use and before cleaning.
- Do not use your appliance with an extension cord unless this cord has been checked and tested by a qualified technician or service person.
- Always use your appliance from a power outlet of the voltage (A.C. only) marked on the appliance.
- This appliance is not intended for use by persons (including children) with reduced physical, sensory or mental capabilities, or lack of experience and knowledge, unless they have been given supervision or instruction concerning use of the appliance by a person responsible for their safety.
- Children should be supervised to ensure that they do not play with the appliance.
- The temperature of accessible surfaces may be high when the appliance is operating.
- Never leave an appliance unattended while in use.
- Do not use an appliance for any purpose other than its intended use.
- Do not place an appliance on or near a hot gas flame, electric element or on a heated oven.
- Do not place on top of any other appliance.
- Do not let the power cord of an appliance hang over the edge of a table or bench top or touch any hot surface.
- Do not operate any electrical appliance with a damaged cord or after the appliance has been damaged in any manner. If damage is suspected, return the appliance to the nearest Sunbeam Appointed Service Centre for examination, repair or adjustment.
- For additional protection, Sunbeam recommend the use of a residual current device (RCD with a tripping current not exceeding 30mA in the electrical circuit supplying power to your appliances.
- Do not immerse the appliance in water or any other liquid unless recommended.
- Appliances are not intended to be operated by means of an external timer or separate remote control system.
- This appliance is intended to be used in household and similar applications such as: staff kitchen areas in shops, offices and other working environments; farm houses; by clients in hotels, motels and other residential type environments; bed and breakfast type environments.

If you have any concerns regarding the performance and use of your appliance, please visit www.sunbeam.com.au or contact the Sunbeam Consumer Service Line.

Ensure the above safety precautions are understood.

Features of your Sunbeam Stainless Deep Fryer

Lid

Featuring a permanent, washable mesh filter that allows steam to escape whilst aiding in the filtration of oil droplets. It also has a large viewing window to monitor your results. Preheat oil with the lid on. Remove lid whilst food is in fryer.

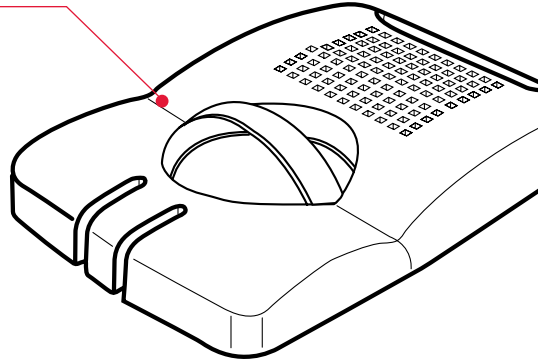

Basket with 1.25kg food capacity

The removable mesh cooking basket has a 1.25kg food capacity. The basket has two frying levels and you can shake it whilst cooking just like a commercial deep fryer. The basket also features a cool touch handle which folds away for easy storage.

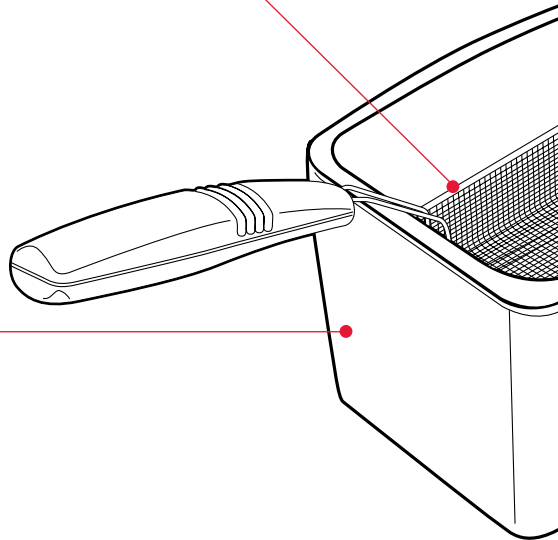

Stainless steel tank

The large stainless steel tank holds an oil capacity of 4.0 litres.

Non slip feet

Keeps the deep fryer secure on the bench, for safer frying.



Cool-Zone

The 2400 watt heating element is suspended in the oil, creating a 'cool-zone' at the bottom of the vessel. This prevents cooking debris burning which will effectively double the useful lifespan of the oil compared with other deep fryers.

Temperature control light

Temperature control light indicates when the deep fryer is heating the oil.

Power on light

The power on light indicates when the deep fryer is switched on.

On/off switch

The on/off switch turns the deep fryer on and off.

Variable thermostat control

The variable thermostat provides a wide range of temperature settings, accurately controlling the temperature of the oil, suiting a range of different foods. The variable control also prolongs the life of the oil.

Reset button

Due to the safety thermostat that switches your fryer off in case of overheating, the reset button allows you to reset your stainless deep fryer once the appliance has cooled down.

Cord storage

For convenient storage, on the back of the control unit there is a compartment for the cord to be kept when not in use.

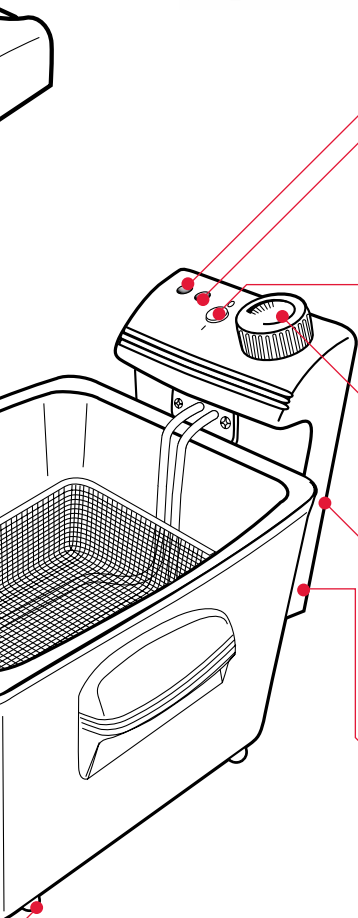

Using your Sunbeam Stainless Deep Fryer

Before using your Stainless Deep Fryer

1. This appliance is designed for household and indoor use only.
2. Before using for the first time, follow the cleaning instructions on page 11 and clean the fryer and basket.

Note: All parts must be dried thoroughly.

3. Place the fryer on a flat and stable surface away from any heating source and where it cannot be splashed with water.
4. Use the carrying handles when moving the product, never carry the appliance by the lid.

Filling your Stainless Deep Fryer

Note: Do not connect the fryer to the electricity supply if there is no oil or fat in the tank.

1. Remove the lid and take out the frying basket. Pull the handle backwards ① until the handle locks into position ②.

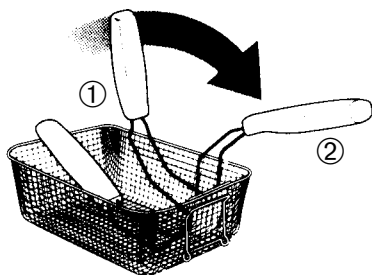

2. Pour good quality vegetable, nut or seed oil into the oil tank until it reaches between the 'MIN' and 'MAX' marks indicated on the inside of the stainless steel tank. Never operate the fryer without oil or with insufficient oil in the tank.

Note: Do not mix different types of oil.

3. Lower the basket into the oil.
4. Replace the lid of the fryer.
5. Insert the plug into a 230 - 240 volt power outlet and turn the power on by using the on/off switch.
6. Rotate the temperature control knob to the temperature that you wish to cook the food. The red indicator light will turn on and the heating element will begin heating the oil.

Safety Feature of the thermostat

Your Stainless Deep Fryer is equipped with a safety thermostat that switches your fryer off in case of overheating.

This will be activated when the desired temperature of the oil is reached, the red indicator light will turn off and the power supplied to the heating element is automatically cut off. The fryer is now ready to cook. When the oil temperature drops, the heating element will switch on automatically.

This may also occur if there is no (or too little) oil in the tank. If the thermostat has switched the fryer off, allow your fryer to cool down and carefully press the reset button concealed in the opening at the back of the fryer ③.

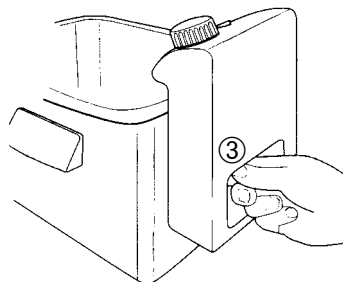

Using your Sunbeam Stainless Deep Fryer continued

Cooking in your Stainless Deep Fryer

There are two methods of cooking in your fryer; one general method for most foodstuffs and another for home battered products.

Note: During the heating up period, steam will build up in the fryer, so when lifting the lid use a kitchen glove or mitt to protect your hand.

General cooking method

(For pre-cooked, crumbed, floured or wrapped food.)

1. Adjust the control dial to the desired temperature. The red temperature indicator light will illuminate.
2. When the oil has reached the required temperature, the light will go out. Remove the lid, lift the basket and put it on the rest ④ so that it is not in contact with the oil. Place the food, (should be as dry as possible) into the raised basket.

Note: The basket should always be in the raised position when it is to be filled with food.

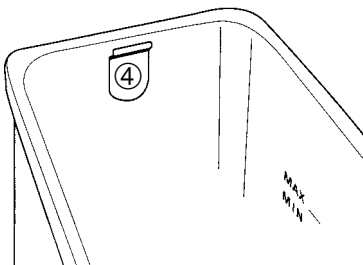

3. Lower the basket into the tank.
4. Do not cook food with the lid on.
5. When the food is cooked (see time guide chart on page 9), place the basket on its raised position to drain for a few seconds.
6. Remove the basket and put the fried food on a plate covered with absorbent paper or kitchen towel.
7. When finished with the fryer, turn the temperature knob to the lowest setting and switch the power off. Remove the plug from mains power.
8. Clean the fryer only after the oil is completely cooled down.

Using your Sunbeam Stainless Deep Fryer continued

Cooking home battered food

This method allows for the fact that if wet batter is placed in the basket prior to cooking the food may stick to the basket. This method of cooking requires extreme care.

1. Adjust the control dial to the desired temperature. The red temperature indicator light will illuminate.
2. When the oil has reached the required temperature the light will go out.

Note: Leave the basket in the down position.

3. Remove the lid of the fryer.
4. Coat the food in batter and allow it to drain slightly to get rid of the excess coating.
5. Very carefully, slowly lower the coated food into the hot oil, using a suitable implement or tongs. This allows the batter to become solid and prevents it sealing to the mesh of the basket.

Note: Remember to take care as the oil may spit as the food is added.

You can now follow the instructions as given in the general cooking method, steps 4 - 8.

Hints for perfect frying

1. Never use the fryer without oil.
2. Always use the best quality oil possible. We recommend corn, nut, seed or vegetable oils. Never use butter, margarine or olive oils.
3. Avoid mixing oils of different qualities or types.
4. Change the oil when it becomes brown or milky in colour.
5. Take into account the food to be cooked before setting the frying temperature. As a general guide precooked food will need a higher temperature than raw food, and the larger the individual items the lower the temperature should be.
6. Large pieces of food should not be deep fried, as they take too long to cook thus absorbing too much oil.
7. Fry small amounts at a time, adding too much at a time will decrease the oil's temperature and increase the chance that food will stick together.
8. Make sure that food is dry before frying, wet food will splatter.
9. Always dry or roll wet food in flour before coating in a batter. Otherwise the extra steam created will separate the coating from the food.
10. Preheat the oil with the lid on.
11. Remove lid whilst cooking.

Frying times and temperatures

FISH AND SEAFOOD

TYPE	MAXIMUM QTY	TEMPERATURE °C	APPROX. TIME (MIN)	SUGGESTIONS
PRAWNS				
Fresh	600g	170C	5-7	Crumb/batter
Frozen	600g	190C	3-5	Fry frozen
FISH				
Small pieces	400g	180C	3-5	Crumb / batter
Fresh fillets	600g	160C	7-10	Crumb / batter
Frozen fillets	600g	160C	5-7	Fry frozen
CALAMARI				
Fresh	500g	170C	5-7	Crumb / batter
Frozen	500g	170C	3-5	Fry frozen

MEAT AND POULTRY

TYPE	MAXIMUM QTY	TEMPERATURE °C	APPROX. TIME (MIN)	SUGGESTIONS
FRESH CHICKEN PORTIONS				
Small	400g	170C	10-15	Crumb or batter
Large	600g	170C	15-20	Crumb or batter
CHICKEN OR VEAL SCHNITZEL				
Fresh	250g	170C	5-10	Crumb
Frozen	250g	180C	3-8	Crumb

Frying times and temperatures continued

VEGETABLES

TYPE	MAXIMUM QTY	TEMPERATURE °C	APPROX. TIME (MIN)	SUGGESTIONS
Beans	200g	180C	2-4	Tempura
Broccoli /Cauliflower	250g	180C	3-5	Tempura or batter
Eggplant (slices)	150g	180C	4-6	Batter
Mushrooms whole button	200g	180C	3-5	Batter
Onion Rings	150g	180C	3-5	Batter
POTATOES				
French fries	500g	180C	4-6	
Chips	500g	180C	5-10	
Wedges	500g	190C	10-15	

Always blanch potato chips at a lower temp. Then brown at 190°C.

Care and Cleaning

Care and Cleaning

Cleaning should only be carried out when the fryer is switched off and the plug removed from the socket. Your fryer should have completely cooled.

Lid and permanent filter

Your Stainless Deep Fryer features a permanent filter that we advise you to clean at regular intervals. Either put the entire lid into the dishwasher or into hot soapy water and let it soak there for 5-10 minutes. Shake the remaining water out of the lid and let it dry.

Basket, handle and removable tank

The basket and its handle can be hand washed in warm soapy water. It should be thoroughly dried afterwards. When the oil has completely cooled, the tank of your fryer can be removed for cleaning by following these instructions:

1. Remove the lid ①, frying basket ② and control unit ③ from the stainless steel tank ④.
2. Remove the stainless steel tank from its shell by placing your finger tips under the rim of the tank.
3. Once removed, drain the oil contained in the tank through a funnel into a suitable container.

Note: Never pour used oil down sink.

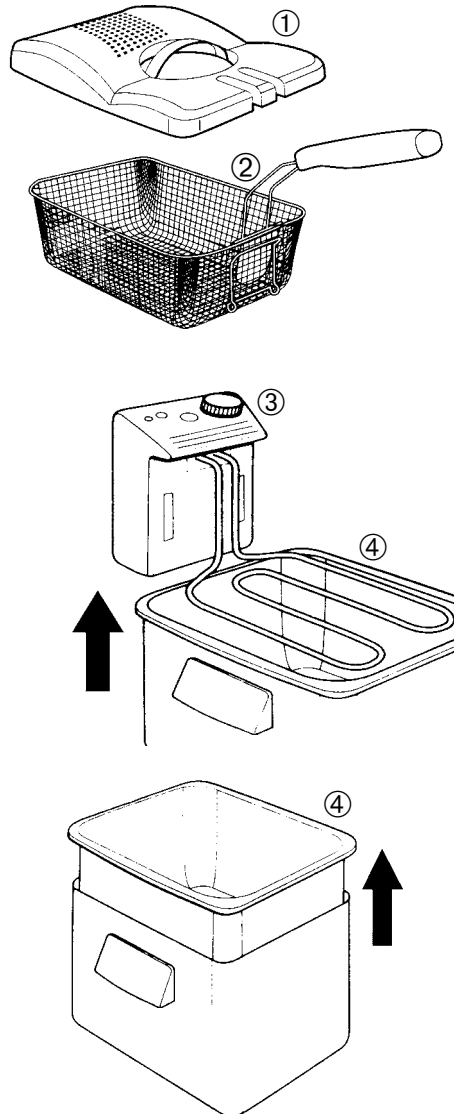

Care and Cleaning continued

4. The fryer body can be washed by hand in hot soapy water and the oil tank in a dishwasher.
5. Dry the tank thoroughly and replace it in the body of your fryer.

Always make sure that the tank is completely dry before you put it back into your fryer.

Note: You may store your filtered oil in the fryer if you make sure that it is covered by the lid.

The control unit

1. Remove the control unit and heating element.

Never immerse the control unit in water or any other liquid.

2. Clean with a damp cloth or kitchen paper.

Ensure that the wires connected to the heating element are not damaged whilst cleaning.

The Perfect Chip

- For perfect fries and wedges, old potatoes are ideal. The potato should be of a low starch, waxy variety i.e. Sebago, Russet Burbank, Spunta, King Edward, Bintje.
- Make sure that the chips are cut to even size to guarantee even cooking.
- The cut chips should be rinsed under running water until the water runs clear. This removes excess starch from the potatoes, the starch burns at high temperatures.
- Dry on kitchen towel before frying.
- Remove the lid whilst cooking.
- Shake the basket at short intervals to encourage even browning and to stop chips sticking together.
- Homemade fries are double cooked. The first fry blanches the chips so that they cook through. The second fry colours the chips and gives them a crisp crust. Use the table below as a guide.

- Cooking times will vary depending on the size of your fries or chips and the variety of the potato used.

PLEASE NOTE: If cooking 1kg of homemade raw potato chips, it is recommended that only 3.5 litres of oil is used.

Hints for cooking the perfect frozen chip.

- Do not defrost frozen pre-cooked chips. For the best results they should be taken directly from the freezer to the fryer.
- Heat oil to the maximum setting, 190°C.
- For best results for frozen chips refer to chip packet.
- Allow chips to drain for a moment before removing from the basket and seasoning.

	1ST FRY (BLANCH)		2ND FRY	
Thin fries - french fries	140°C	5 min	190°C	5 min
Thick chips	140°C	7-8 min	190°C	7-8 min
Wedges	140°C	10 min	180°C	10 min

Allow oil to heat up to 2nd temperature before re-immersing the basket in the hot oil.

Recipes

For Perfect Batter

1. Always sift all dry ingredients, then add liquids. Mix until smooth.
2. Keep your batter as cold as possible (it will be crisper).
3. Coat food in seasoned flour before batter, the batter will stick to the food better.
4. Fry until golden brown.
5. Always use the 'Cooking Home Battered Food' technique, see page 8 for more information.

Beer Batter

- 1 cup plain flour
- ½ teaspoon baking powder
- pinch salt
- ¾ cup cold beer

Crispy Sesame Batter

- 1 cup cornflour
- 2 eggs
- ⅓ cup water (cold)
- 2 tablespoon sesame seeds

Sweet Fritter Batter

- 1 egg
- ⅔ cup milk
- 1 cup self raising flour
- 1 tablespoon sugar
- 1 tablespoon melted butter or margarine

Tempura Batter

- ½ cup plain flour
- ¼ cup rice flour
- 1 teaspoon bicarb soda
- 1 cup soda water (ice cold)
- 1 egg

Note: It's very important to keep this batter cold. A good tip is to chill all ingredients before use.

Easy Crispy Coating

- 1 egg
 - 1 tablespoon water or milk
 - 1 cup rice flour or cornflour
 - pinch of salt/pepper
1. Beat egg and water or milk. Season flour with salt and pepper.
 2. Dip food in egg mix and then coat with flour.
 3. Deep fry at 170°C to 190°C depending on size of foodstuff, until crispy, this coating will not colour much. Remove the lid whilst cooking.

Recipes continued

Prawn Cutlets

750g green king prawns

plain flour

1 egg, lightly beaten

2 cups fresh breadcrumbs

lemon wedges to serve

1. Peel and devein prawns, leaving tails intact. Dry thoroughly.
2. Coat prawns in flour, then egg, then breadcrumbs. Shake off excess crumbs.
3. Heat the oil to 180°C and fry cutlets for 4-5 minutes until golden brown. Remove the lid whilst cooking.
4. Drain and serve immediately with lemon wedges.

Deep Fried Pork Balls Makes 14 to 16 balls

500g minced pork

2 tablespoon plain flour

2 tablespoon cornflour

1 tablespoon soy sauce

1 teaspoon garlic salt

1 teaspoon ground black pepper

1 egg, lightly beaten

1. Combine all ingredients in a large bowl, mix thoroughly. Picking up mixture slap against the side of the bowl until the mix seems more elastic or sticky. This should only take a few slaps.
2. Shape mixture into 4cm balls.
3. Heat oil to 180°C. Place pork balls in the basket 5-6 at a time, cook for 8-10 minutes until golden brown. Remove the lid whilst cooking.
4. Drain. Serve with sweet and sour sauce and fried or steamed rice if desired.

Recipes continued

Calamari

500g squid, washed and cleaned

½ cup plain flour

1 egg, lightly beaten

1 cup dried breadcrumbs

1. Remove the insides and head of the squid. Wash and dry thoroughly.
2. Cut the squid tubes into 1cm rings.
3. Coat the squid pieces in flour, egg and then breadcrumbs.
4. Heat the oil to 170°C and fry the squid until golden brown. Remove the lid whilst cooking.
5. Drain and serve immediately with tartare sauce and lemon wedges.

Tartare Sauce

250ml of good quality mayonnaise with 1 tablespoon chopped tarragon and parsley, a ½ tablespoon of capers and 1 tablespoon of chopped gerkins. Season with salt and pepper to taste.

Dim Sims

125g small green prawns, shelled and deveined

500g minced pork

½ cup chopped bamboo shoots

½ cup chopped water chestnuts

1 onion, finely chopped

1 tablespoon sherry

1 tablespoon soy sauce

1 teaspoon salt pinch pepper

40 gow gee wrappers

1. Finely chop prawns and combine with pork.
2. Add all other ingredients and mix well to combine.
3. Place 1 heaped teaspoon of pork mixture onto the centre of each wrapper and gather the sides of the wrapper around the filling, leaving a small opening at the top.
4. Heat the oil to 180°C and deep fry about 10 at a time, until golden brown, about 4-5minutes. Remove the lid whilst cooking.
5. Drain and serve with sweet and sour sauce if desired.

Recipes continued

Spring Rolls

Makes about 24 rolls

500g green prawns, shelled and deveined

500g minced pork

½ small head of cabbage, thinly shredded

230g can of water chestnuts, drained and finely chopped

125g fresh shitake mushrooms, roughly chopped

1 green capsicum, seeded and finely chopped

1 onion, peeled and finely chopped

2 tablespoon dry sherry

2 tablespoon soy sauce

1 teaspoon sugar

½ teaspoon salt

¼ teaspoon ground ginger

455g packet spring roll wrappers

1 egg, lightly beaten with 2 tablespoons water

1. Finely chop prawns and combine with pork.
2. Add cabbage, water chestnuts, mushrooms, capsicum, onion, sherry, soy, sugar, salt and ginger. Mix well to combine.
3. Place 2-3 tablespoon of the pork mixture in the corner of a spring roll wrapper. Roll the wrapper folding in the sides to encase the filling.
4. Brush a little egg mix on the end of wrapper to help it seal.
5. Heat oil to 180°C, deep fry until golden brown, about 5 minutes. Remove the lid whilst cooking.
6. Drain and serve with dipping sauce.

Minted Pea Wontons

3 medium potatoes, peeled and cut into 5mm dice

1 onion, peeled and finely chopped

2 teaspoon oil

1 teaspoon ground cumin

220g can peas

¼ cup mint, chopped

125g wonton wrappers

1. Boil the diced potato until just cooked. Drain.
2. In a saucepan cook onion in oil until soft add cumin and peas and rough mash. Remove from heat.
3. Add potato and mint. Stir to combine.
4. Place about 2tsp of mix onto each wonton wrapper and bring edges together. Seal with a light brush of water.
5. Heat fryer to 190°C, and deep fry until golden brown, about 3-4 minutes. Remove the lid whilst cooking.
6. Serve with minted yoghurt if desired.

Recipes continued

Southern Fried Chicken Makes 4 - 6 servings

750g chicken drumsticks

½ cup flour

½ teaspoon salt

½ teaspoon hot paprika (optional)

1 egg, beaten with 2 tablespoons water

1 cup dried breadcrumbs

1. Mix flour with salt and paprika. Dry drumsticks and coat in seasoned flour.
2. Dip each drumstick into egg mixture separately and coat in breadcrumbs.
3. Heat oil to 170°C.
4. Place 3 - 4 drumsticks into the basket at a time and fry till cooked through and golden, about 15 to 20 minutes. Remove the lid whilst cooking.
5. Drain well and keep hot while other pieces are cooking.

Classic Buffalo Wings Makes 32 wings

16 small chicken wings

⅓ cup Maggi hot chilli sauce

80g butter

Blue cheese dressing or

Ranch dressing for dipping

1. Cut tips from chicken wings and discard. Cut wings in half at joint.
2. Heat oil in fryer to 190°C.
3. Combine the chilli sauce and butter and whisk through to combine.
4. Deep fry wings in batches until wings are crisp and cooked through. Remove the lid whilst cooking. Drain well. Keep wings warm while cooking remaining batches.
5. Place wings in a large bowl and toss through chilli sauce.
6. Serve wings with blue cheese or ranch dressing.

Recipes continued

Potato dumplings

Makes approx. 25-30

60g butter

1¼ cups water

1 teaspoon salt

1 cup plain flour, sifted

3 eggs

4 medium potatoes, peeled, cooked and mashed.

1. Place butter salt and water into a saucepan and bring to the boil.
2. Add the sifted flour all at once and stir vigorously with a wooden spoon over a low to medium heat, until the dough forms and pulls away from the edges of the pan. Remove from heat and set aside to cool for 5 minutes.
3. Add eggs one at a time to the dough, beating well between additions. The dough should look smooth and shiny.
4. Add mash to dough and beat mixture until smooth.
5. Heat fryer to 170°C.
6. Using two spoons scoop heaped balls of mixture into the fryer basket. Remove the lid whilst cooking. Deep fry about 8 at a time for 4-5 minutes, and golden brown.

Fried Cheese Scones

Filling

2 leeks, finely sliced

20g butter

100g grated gryere or cheddar cheese

1 egg

¼ cup cream

salt and pepper

Dough

30g butter, diced

1½ cups self-raising flour

½ teaspoon salt

¾ cup milk

1. For filling. Saute leeks in 1tbsp of butter until soft. Remove from the heat and mix through cheese, egg, and cream. Season and set aside to cool.
2. For Dough. Place butter, flour and salt in a bowl and rub the mixture between fingertips until it resembles fine breadcrumbs. Add milk and bring dough together.
3. Turn dough out onto a floured bench and knead lightly for 2-3 minutes.
4. Take about 2 tablespoons of the dough at a time and work into a flat circle. Place 1 teaspoon of the filling in the centre and work edges together, pinching to seal. Be careful to keep the thickness of the dough as even as possible.
5. Heat oil to 160°C, frying about 8 at a time until puffy and golden. Remove the lid whilst cooking.
6. Drain and serve hot.

Recipes continue

Fried Mozzarella Sticks

185g Mozzarella cheese
2 tablespoons milk
¼ cup plain flour
1 egg, lightly beaten
1 cup Japanese breadcrumbs
sea salt and freshly ground black pepper
1 ½ cups Italian tomato sauce

1. Cut Mozzarella into 1½ cm thick sticks.
2. Dip the sticks into the milk then flour; shake off excess.
3. Dip sticks into the egg then coat into the flour seasoned with salt and pepper.
4. Place coated sticks onto a tray and place into the freezer for about 25 minutes.
5. Heat oil to 170°C. Deep fry for about 30 seconds or until the crumbs are golden; drain on absorbent paper. Remove the lid whilst cooking.
6. Serve with warmed tomato sauce.

Note: Japanese breadcrumbs are available from Asian grocers or good supermarkets.

Green Onion and Sesame Puffs

1 tablespoon vegetable oil
1 teaspoon fresh grated ginger
1 clove garlic crushed
12 green onions, sliced
½ cup sesame seeds
2 tablespoon oyster sauce
2 sheets ready rolled shortcrust pastry
1 egg yolk, beaten
extra sesame seeds

1. Heat oil in a wok, add ginger, garlic, shallots and sesame seeds. Stir fry for 1 minute, add oyster sauce. Remove from heat set aside to cool.
2. Cut 8 cm² (squares) from pastry sheets
3. Place a tablespoon of onion mixture into each square, glaze edges with egg. Bring the four corners to the centre and pinch edges to seal.
4. Glaze with remaining egg and sprinkle lightly with extra sesame seeds.
5. Heat oil to 180°C and fry till golden brown, about 4 minutes. Remove the lid whilst cooking.

Recipes continued

Meat Fritters

Makes 12 fritters

1 cup self raising flour

salt and pepper

1 egg

2 tablespoon oil

¼ cup water

½ – ¾ cup milk

2 cups cooked, diced leftover meat (beef, pork, lamb, chicken)

1 onion, chopped finely

1. Place the flour, salt and pepper into a small mixing bowl. Add egg, oil and water, mix till smooth.
2. Beat in milk as required to form a loose batter. Add meat and onion.
3. Heat oil to 160°C. Spoon batter into the hot oil. Remove the lid whilst cooking. Cook until golden brown, about 5 minutes.
4. Drain and serve with reheated leftover gravy.

Meatballs

Makes about 18

750g minced topside steak

1 onion, chopped

½ cup breadcrumbs

2 tablespoons chopped parsley

½ teaspoon salt

½ teaspoon pepper

½ teaspoon dried mixed herbs

2 teaspoons Worcestershire sauce

1 egg, lightly beaten

1. Combine meat, onion, breadcrumbs, parsley, seasoning, and Worcestershire sauce.
2. Add enough egg to bind mixture together.
3. Shape the mixture into 25mm balls, refrigerate meatballs for 1 hour.
4. Heat oil to 160°C
5. Remove the lid whilst cooking. Fry for 6-7 minutes, till golden. Drain and serve with a spicy dipping sauce.

Recipes continued

Potato Crisps

4 potatoes, washed and peeled

2 cups water, salted

1. Cut potatoes into wafer thin slices. Place the slices into the salted water and allow to stand for 1-2 hours.
2. Drain potatoes and dry thoroughly.
3. Heat oil to 180°C and fry a small quantity at a time, shaking frequently during cooking. Cook for 3-4 minutes.
4. Drain and serve hot or cold, sprinkle with salt if desired.

Felafel

1½ cup dried chickpeas, washed and soaking

1 onion chopped

½ teaspoon chilli powder

1 teaspoon cumin, ground

½ teaspoon coriander, ground

2 cloves garlic, crushed

3 teaspoons lemon juice

¼ cup chopped parsley

½ cup besan flour (chickpea)

1 egg

1. Soak chickpeas overnight, drain. Rinse well.
2. Place chickpeas in a saucepan with 1 litre of water, simmer for 1 hour. Drain well.
3. Blend the chickpeas with the rest of the ingredients in a food processor. Chilli mixture.
4. Heat oil to 160°C. Shape felafel into 4cm balls and fry 8- 10 at a time for 3-4 minutes. Remove the lid whilst cooking.
5. Sever hot or cold with hummus and Lebanese bread.

Recipes continued

Corn Fritters

Makes about 12

$\frac{3}{4}$ cup self raising flour

pinch of salt

pinch of pepper

1 egg, lightly beaten

$\frac{1}{3}$ cup milk

300g can of corn kernels, drained

1. Sift flour, salt and pepper into a bowl.
2. Combine egg and milk.
3. Using a mixer, gradually add milk mix to the dry ingredients and beat until smooth. Add corn to mix.
4. Heat the oil to 180°C. Drop batter by the tablespoonful into the hot oil and fry till golden, about 5-7 minutes. Remove the lid whilst cooking.

Kofte Potatoes

500g potatoes, cooked and mashed

2 eggs

$\frac{1}{3}$ cup desiccated coconut

1 cup grated Parmesan cheese

salt and pepper

2 tablespoon flour

2 eggs, lightly beaten

1 cup dried breadcrumbs

1. Combine the first five ingredients.
2. Coat 1 tablespoon of the mixture in flour, then egg mix and then in breadcrumbs. Repeat with remaining mixture.
3. Heat oil to 170°C and fry 6 - 8 at a time till golden, about 4-5 minutes. Remove the lid whilst cooking.

NOTE: for something different use sweet potato or pumpkin in place of the potato.

Recipes continued

Apple Fritters

Serves 4

2 apples, peeled and sliced into 5mm thick rings.

½ cup plain flour

Fritter batter (see page 14)

2 tablespoon caster sugar

½ teaspoon ground cinnamon

ice cream to serve

1. Heat oil to 170°C.
2. Coat apple slices in flour and then dip in batter. Fry for 4-5 minutes and golden. Remove the lid whilst cooking.
3. Drain and toss in cinnamon sugar. Serve with ice cream.

Strawberry Stack

Serves 4

12 wonton wrappers

1 cup thickened cream

2 tablespoon sugar

½ teaspoon vanilla extract

250g punnet strawberries, hulled and halved
icing sugar to dust

1. Heat oil to 180°C.
2. Remove the lid whilst cooking. Fry wonton wrappers, a couple at a time, until just coloured. Drain on absorbent paper.
3. To serve stack crispy wrappers with strawberries, and sweetened whipped cream. Dust top with icing sugar.

Recipes continued

Buttermilk Doughnuts

- 2 teaspoons dry yeast
- 1 ¼ cups buttermilk
- ¼ cup caster sugar
- 4 cups plain flour
- 1 teaspoon salt
- ¼ cup light olive oil
- 2 eggs, lightly beaten

Cinnamon Sugar

- 1 cup caster sugar
- 2 teaspoons ground cinnamon

1. In a small bowl, whisk the yeast into the warmed buttermilk with 1 tablespoon of the sugar. Mix well and stand in a warm place for 1 minutes or until the mixture begins to bubble.
2. Sift the remaining sugar, flour and salt into a large bowl. Make a well in the centre and mix through the oil, eggs and yeast mixture. Mix to a soft dough.
3. Place mixture onto a lightly floured surface and knead dough for about 10 minutes or until dough is smooth and elastic.
4. Place dough in a bowl; cover, and stand in a warm place for about 40 minutes or until dough has doubled in size.
5. Turn dough onto a lightly floured surface and knead again for about 5 minutes or until smooth and elastic. Roll dough out to a 1 cm thickness for a thinner doughnut or to a 1½ cm thickness for a thicker doughnut. To cut doughnuts use either a doughnut cutter or a 9cm cutter and a 3cm cutter. Place doughnuts onto a tray lined with baking paper and cover with plastic wrap, stand in a warm place for about 20 minutes.
6. Heat oil to 160°C. Remove the lid whilst cooking. Cook doughnuts, in batches, turning once during cooking, until golden in colour.
7. Drain doughnuts on absorbent paper then toss in cinnamon sugar mixture.

Troubleshooting

PROBLEM	POSSIBLE CAUSE	SOLUTION
Strong smell	Oil has gone bad.	Replace oil.
	The correct oil is not being used.	Use only high quality oil. Do not mix oils of a different quality or type.
Oil overflowing	Fryer is filled above the maximum level.	Check oil level on the inside of fryer.
	Wet food placed in hot oil.	Dry food first.
	Stated quantities exceeded.	Do not fry food above the weight indicated.
Food is not browning	Cooking temperature is too low.	Adjust the dial to the correct cooking temperature.
	Basket is overloaded.	Do not fry food above the stated quantities and weights.
	Oil is not hot enough.	Faulty thermostat. Consult Service Centre.
Chips are sticking together	Food not washed thoroughly before placed in the oil.	Wash potatoes thoroughly and dry before frying.
Appliance not working	Appliance has been turned on without fat or oil.	Allow the fryer to cool down, fill with oil and press the reset button that is concealed at the back of the fryer.
	Temperature control dial not at correct setting.	Choose cooking temperature.

12 Month Replacement Guarantee

In the unlikely event that this appliance develops any malfunction within 12 months of purchase (3 months commercial use) due to faulty materials or manufacture, we will replace it for you free of charge.

Should you experience any difficulties with your appliance, please phone our customer service line for advice on 1300 881 861 in Australia, or 0800 786 232 in New Zealand. Alternatively, you can send a written claim to Sunbeam at the address listed below. On receipt of your claim, Sunbeam will seek to resolve your difficulties or, if the appliance is defective, advise you on how to obtain a replacement or refund.

Your Sunbeam 12 Month Replacement Guarantee naturally does not cover misuse or negligent handling and normal wear and tear.

Similarly your 12 Month Replacement Guarantee does not cover freight or any other costs incurred in making a claim. Please retain your receipt as proof of purchase.

The benefits given to you by this guarantee are in addition to your other rights and remedies under any laws which relate to the appliance.

Our goods come with guarantees that cannot be excluded under the Australian Consumer Law and under the New Zealand Consumer Guarantees Act.

In Australia you are entitled to a replacement or refund for a major failure and for compensation for any other reasonably foreseeable loss or damage. You are also entitled to have the goods repaired or replaced if the goods fail to be of acceptable quality and the failure does not amount to a major failure.

Should your appliance require repair or service after the guarantee period, contact your nearest Sunbeam service centre.

For a complete list of Sunbeam's authorised service centres visit our website or call:

Australia

www.sunbeam.com.au

1300 881 861

Units 5 & 6, 13 Lord Street
Botany NSW 2019 Australia

New Zealand

www.sunbeam.co.nz

0800 786 232

26 Vestey Drive, Mt Wellington
Auckland, New Zealand

Need help with your appliance?

Contact our customer service team or visit our website for information and tips on getting the most from your appliance.

In Australia

Visit www.sunbeam.com.au

Or call 1300 881 861

In New Zealand

Visit www.sunbeam.co.nz

Or call 0800 786 232

 is a registered trademark.

Made in China.

Due to minor changes in design or otherwise, the product may differ from the one shown in this leaflet.

© Copyright. Sunbeam Corporation Limited 2004.

ABN 45 000 006 771

Units 5 & 6, 13 Lord Street
Botany NSW 2019 Australia

Unit 3, Building D
26 Vestey Drive
Mt Wellington Auckland
New Zealand

Sunbeam Corporation is a division of GUD Holdings Ltd.